

Technical Information

Flow Dividers and Gear Motors

1FDF / 1AFDF / 2FDF / 3FDF

1MF / 1AMF / 2MF / 2.5MF / 3MF / 3.5MF

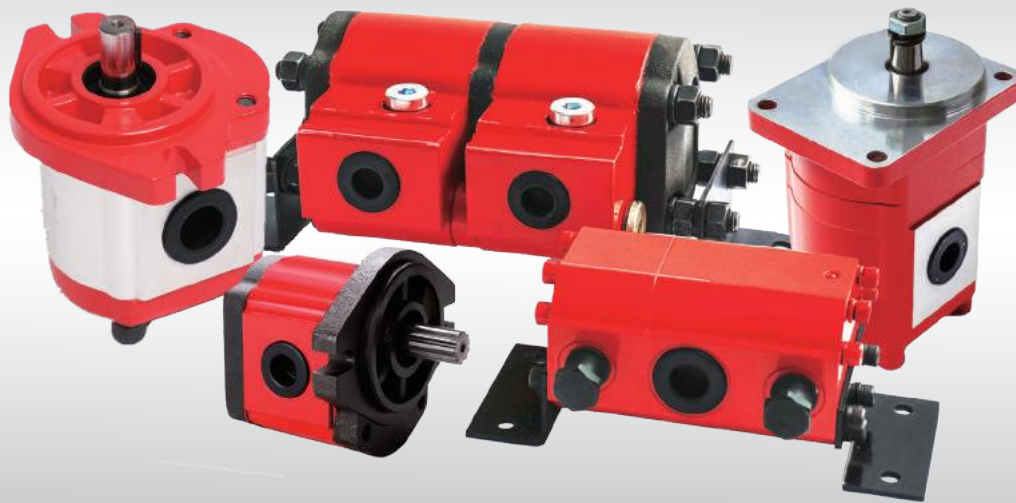



RYAN HYDRAULICS

Keep the concept seeking excellence.
RYAN try our best to create more value for you with products and service.

RYAN Hydraulics

About RYAN

RYAN's manufacturing base was established in 1986, with quality hydraulic components and solutions to hydraulic system in the applications of engineering machinery, mobile industries, agricultural machinery, aviation, mining, and other fields. Main products include gear pump, gear motor, flow divider, orbital motor, loadsensing proportional valve, monoblock valve, sectional valve, manifold assembly and hydraulic power unit as well.

Long-term Development Strategy

Reducing emissions by new energy is one of RYAN's long-term strategies. RYAN will be providing innovative technologies, products, and services for the global development of new energy, moving towards a century development strategy, and writing a century-new chapter in the hydraulic field.



Innovation leads the future

Through a few decades of development, RYAN's manufacturing base has built an intelligent manufacturing factory, gathering international R&D talents, accumulating rich R&D and manufacturing experience, possessing independent intellectual property rights, continuously providing customers with new products and technologies, and creating value for all of the customers.

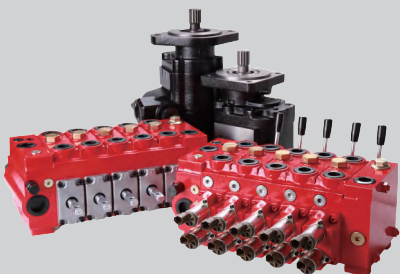

Flow Dividers and Gear Motors

	04-09	L Flow Dividers
Gear Motors L	10-27	

Flow Dividers

	04	L Introduction of Flow Dividers
Ordering Code L	04	
	05	L ★0FDF Flow Dividers
1FDF Flow Dividers L	06	
	07	L 1AFDF Flow Dividers
2FDF Flow Dividers L	08	
	07	L 3FDF Flow Dividers

Introduction of Flow Dividers

Two or several gear motors can be combined into flow divider after being connected by coupling. It guarantees synchronous operation and accuracy of power element like cylinder (Its principle drawing is as follows), hydraulic liquid from the pipe is input into the inlet port and the same amount liquid is distributed to the outlet port by the rotation of gears that with same specification. Obviously, accuracy of flow divider is up to accuracy of gears and relative spare parts.

GRH has three series for flow divider 0PF, 1FDF, 2FDF, 3FDF. Flow accuracy and pressure loss are as follows:

Type	Flow Accuracy	Pressure Drop
0FDF	$\pm 1.5\% - \pm 2\%$	16-19bar
1FDF	$\pm 1.5\% - \pm 2\%$	16-19bar
2FDF	$\pm 1.5\% - \pm 2\%$	11-14bar
3FDF	$\pm 1.5\% - \pm 2\%$	11-14bar

It should be noted that flow accuracy is also related to the factors below: system pressure, viscosity of hydraulic liquid, load that each function unit bears and overall flow. These factors should be taken into account at time of application.

Flow divider can be integrated with relief valve, check valve and throttle valve, protecting system pressure and filling the oil. For specific requirements, please contact GRH.

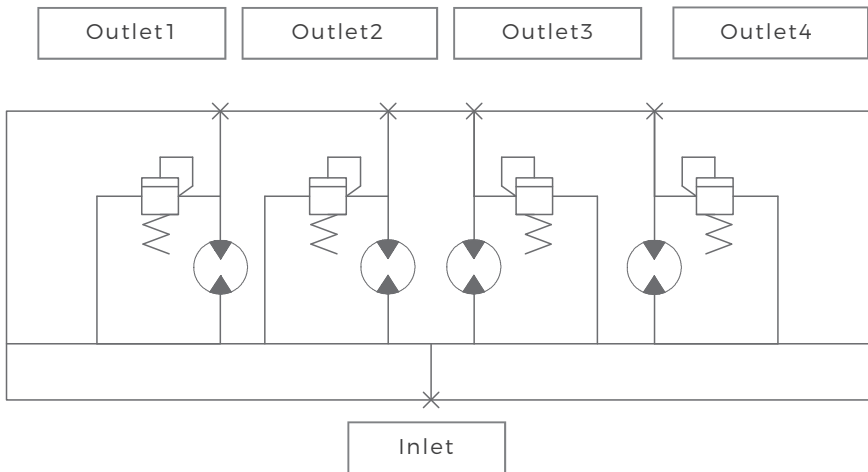

Ordering Code

3	FD	F	60	L71	-4	-1
a	b	c	d	e	f	g

Ⓐ Model: Group 0,1, 2, 3

Ⓑ Function: Flow Divider

Ⓒ F: Version

Ⓓ Displacement: 0.76-70ml/r

Ⓔ Inlet/Outlet Combination

Ⓕ Number of Section: 1-8

Ⓖ Number of Inlet: 1-4



0FDF0.75L44-4-2 Flow Dividers

Series	Displacement (ml/r)	Flow (L/min)	Pressure (bar)		Section	Synchronization accuracy
			100	150		
0FDF	0.75	0.75-3	100	150	4	≤3%

Dimensions

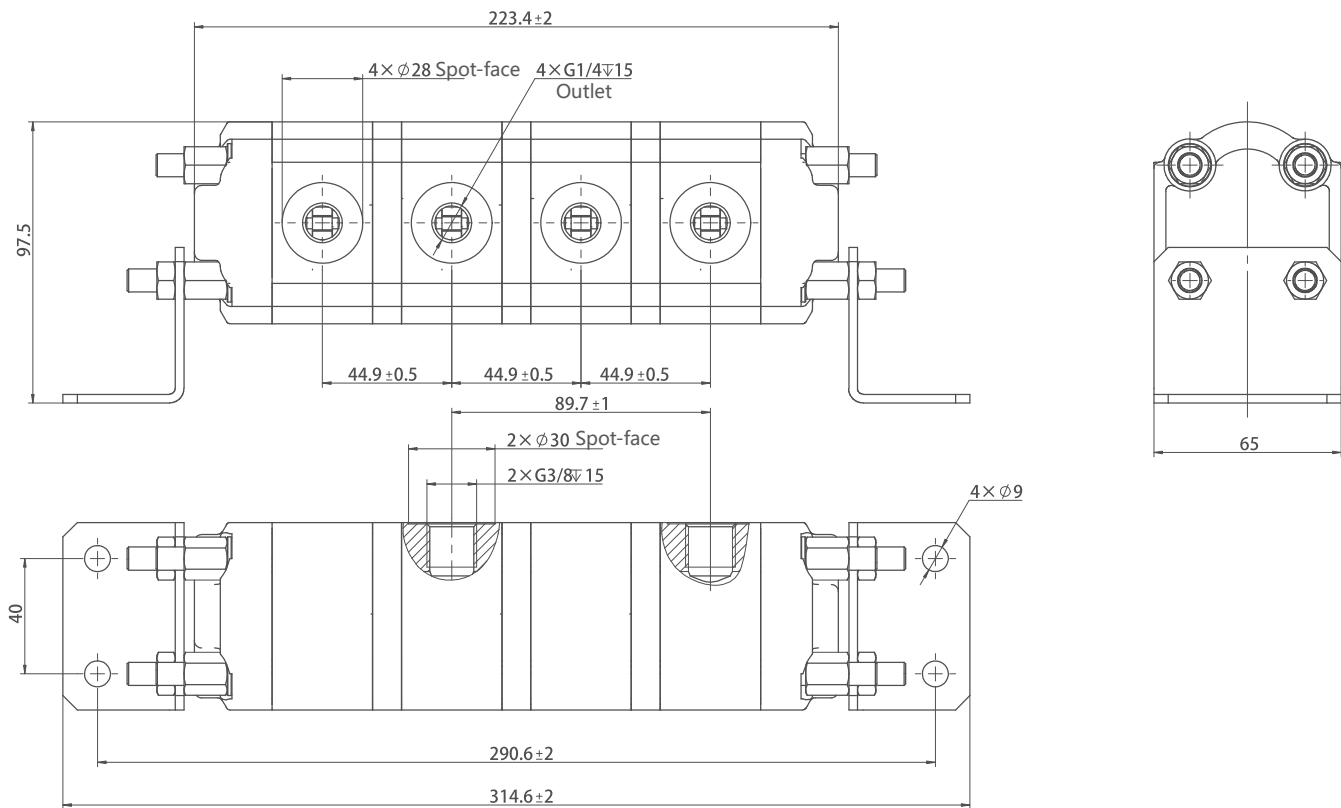

Schematic Diagram

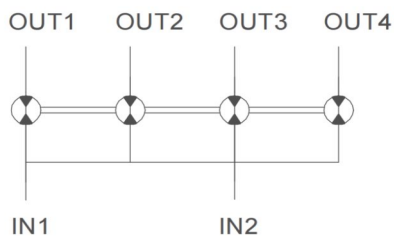

1FDF**L**-2/4 Flow Dividers

Displacement		Speed		Flow range/ each section				Min.system pressure		Max.pressure of oil outlet			
in ³ /r	ml/r	min. (rpm)	max. (rpm)	gpm		lpm		psi	bar	psi	bar		
0.097	1.6	1000	3000	0.42	1.25	1.6	6.72	870	60	3480	240		
0.122	2			0.52	2.2	2	8.4			3480	240		
0.195	3.2			0.84	3.52	3.2	13.44			3480	240		
0.244	4			3500	3500	1.05	4.41	4	16.8	580	40	3480	240
0.305	5					1.31	5.51	5	21			3480	240
0.366	6					1.57	5.51	6	21			3480	240
0.427	7	1.84	6.43			7	24.5	3480	240				
0.488	8			2.10	7.34	8	28			3480	240		

Dimensions

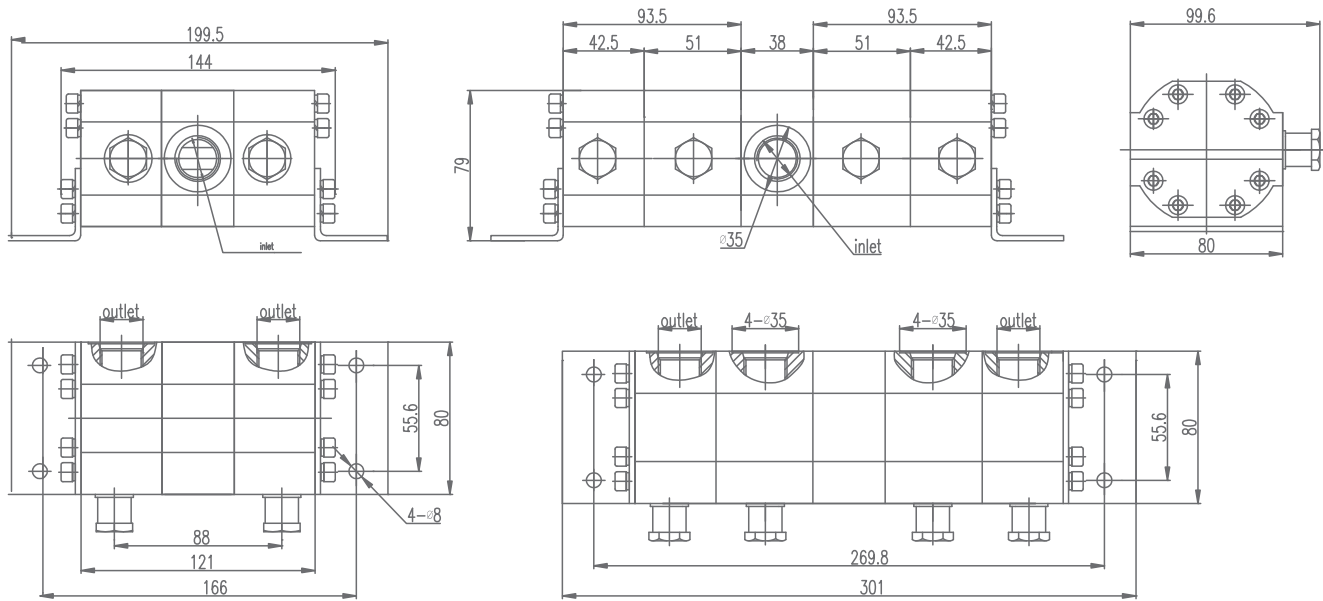

Schematic Diagrams

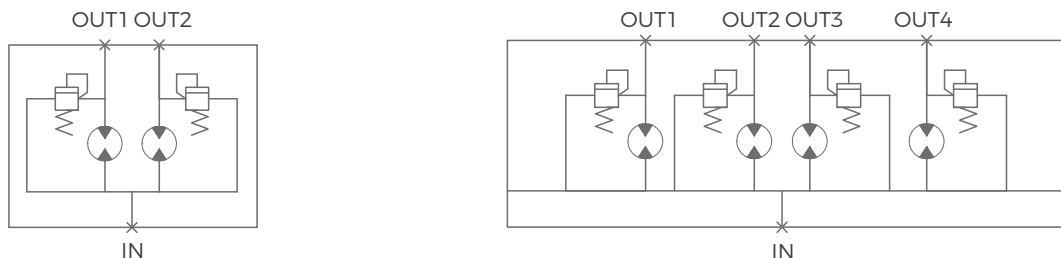



1AFDF**L**- Y-V Flow Dividers

Displacement		Speed		Flow range/ each section				Min.system pressure		Max.pressure of oil outlet	
in ³ /r	ml/r	min. (rpm)	max. (rpm)	gpm		lpm		psi	bar	psi	bar
0.103	1.7	800	3000	0.35	1.33	1.36	5.1	1160	80	3480	240
0.122	2			0.42	1.57	1.6	6			3480	240
0.146	2.4			0.5	1.88	1.92	7.2			3480	240
0.164	2.7			0.56	2.12	2.16	8.1			3480	240
0.183	3			0.63	2.36	2.4	9			3480	240
0.207	3.4			0.71	2.68	2.72	10.2			3480	240
0.250	4.1			725	50	0.86	3.23	3.28	12.3	3480	240
0.311	5.1					1.07	4.01	4.08	15.3	3480	240
0.372	6.1					1.28	4.8	4.88	18.3	3480	240
0.433	7.1					1.49	5.59	5.68	21.3	3480	240
0.488	8					1.68	6.3	6.4	24	3480	240

Dimensions

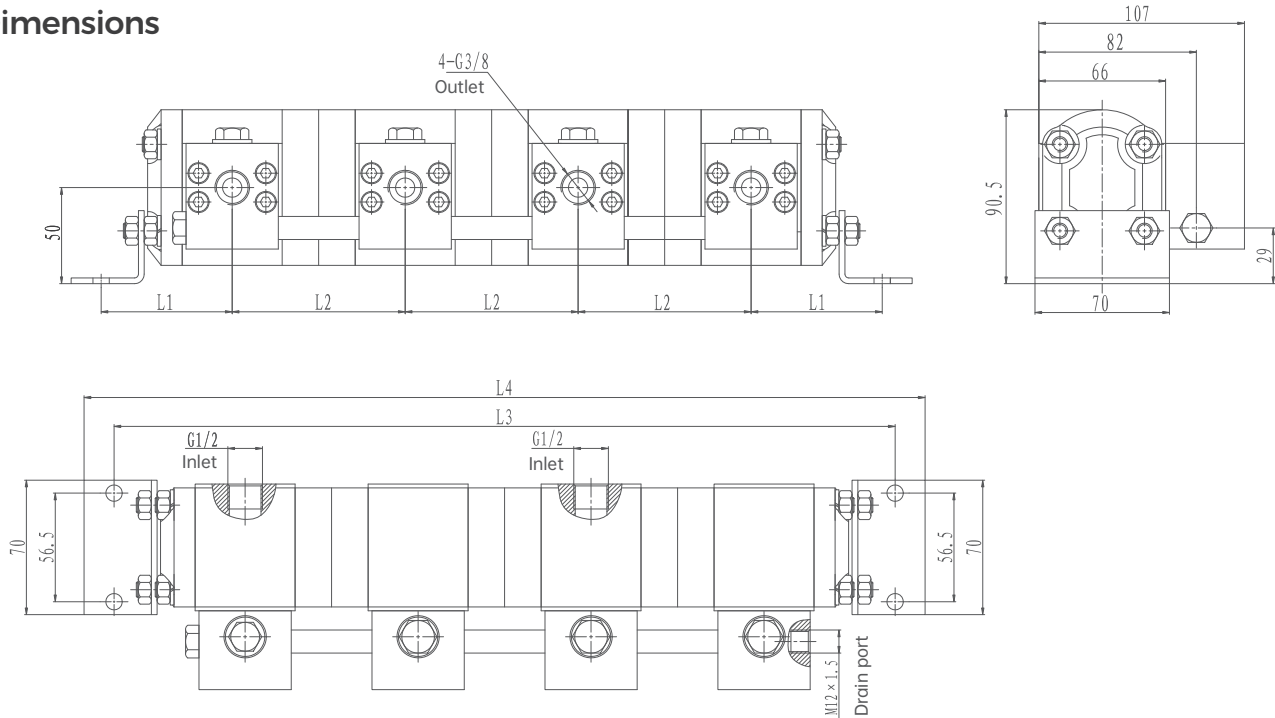

Schematic Diagrams

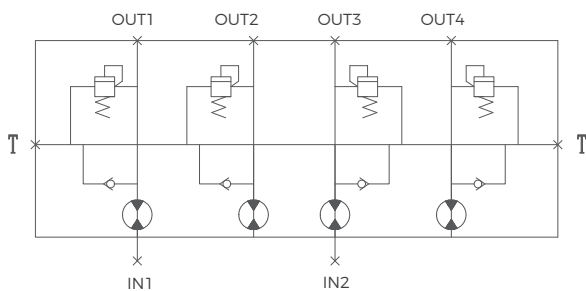

2FDF**L**-2/4 Flow Dividers

Displacement		Speed		Flow range/ each section				Min.system pressure		Max.pressure of oil outlet		
in ³ /r	ml/r	min. (rpm)	max. (rpm)	gpm		lpm		psi	bar	psi	bar	
0.366	6	800	3500	1.26	5.51	4.8	21	1160	80	3625	250	
0.488	8			1.68	7.34	6.4	28			3625	250	
0.671	11			2.31	10.1	8.8	38.5			3625	250	
0.732	12			2.52	11.02	9.6	42			3190	220	
0.854	14			3000	2.94	11.02	11.2			42	3190	220
1.037	17				3.57	13.38	13.6			51	3190	220
1.525	25	2500	5.25		16.39	20	62.5	3190	220			
1.891	31		6.51	20.33	24.8	77.5	2610	180				

Dimensions

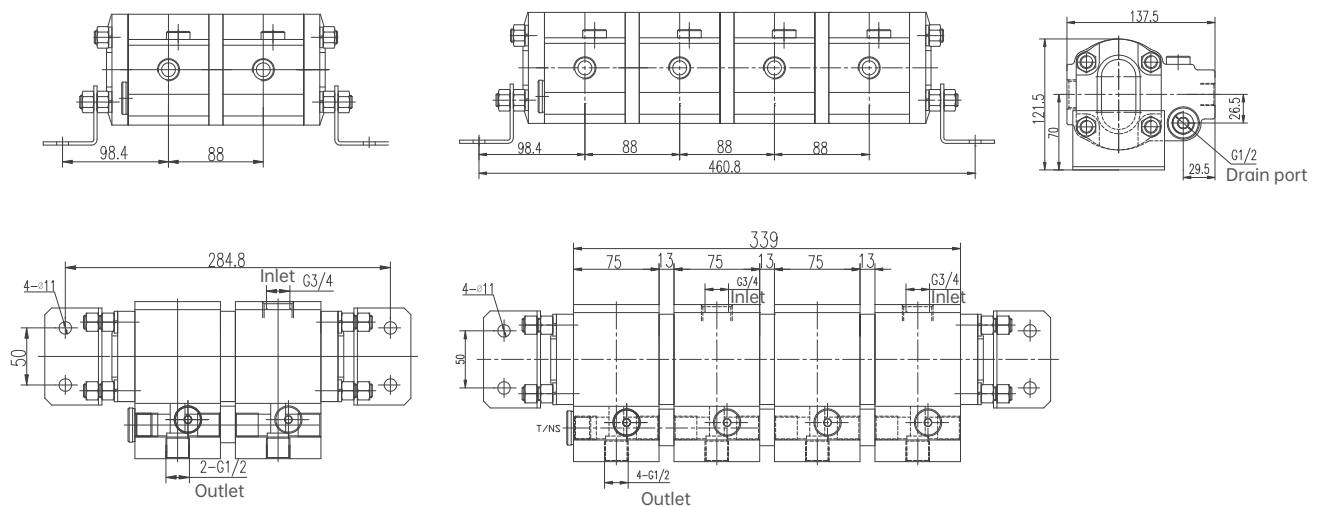

Schematic Diagrams

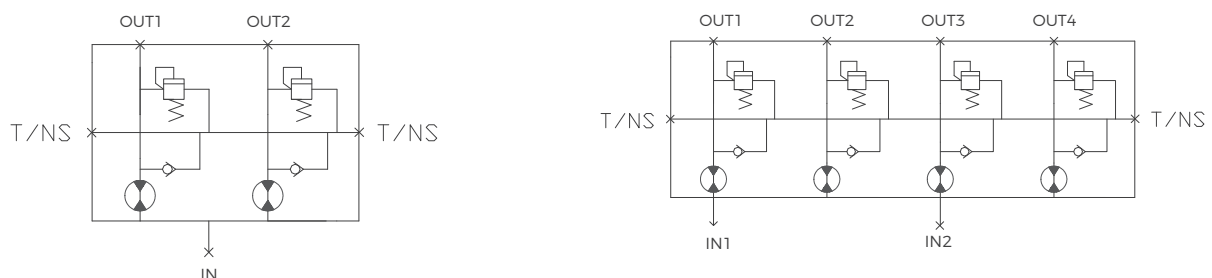

3FDF**L**-* Flow Dividers

Displacement		Speed		Flow range/ each section				Min.system pressure		Max.pressure of oil outlet	
in ³ /r	ml/r			gpm		lpm		psi	bar	psi	bar
1.22	20	800	2500	4.2	13.12	16	50	870	60	3480	240
1.647	27			5.67	17.71	21.6	67.5			3480	240
1.83	30			6.3	19.67	24	75			3480	240
2.379	39			8.18	25.57	31.2	97.5			3480	240
3.05	50			10.49	32.79	40	125	725	50	3480	240
3.355	55			11.54	36.07	44	137.5			3335	230
3.66	60			12.59	39.35	48	150			2900	200
4.27	70			14.69	45.9	56	175			2610	180

Dimensions

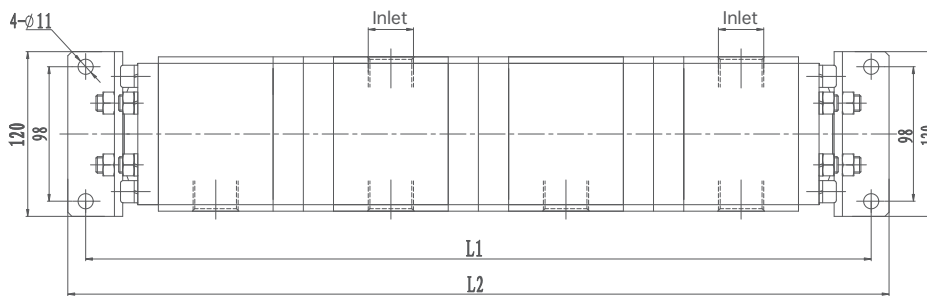
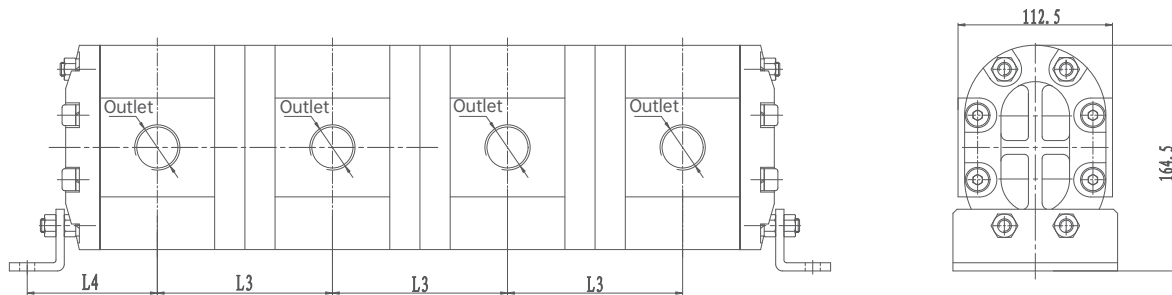

Schematic Diagrams

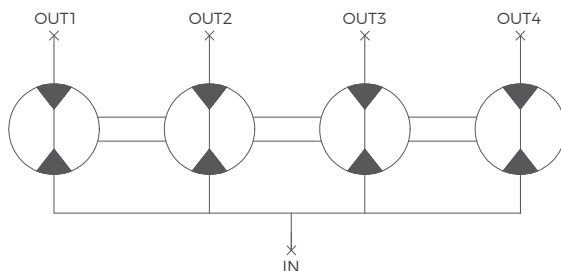

Gear Motors

Introduction	└	11-12	
		13	└ Specifications
Ordering Code	└	14	
		15	└ 1MF/1AMF/1DMF Bi-direction
2MF Bi-direction	└	16-17	
		18	└ 2SMG
2.5MF/3MF Bi-direction	└	19	
		20	└ 2.8QMF
3.5QMF	└	21	
		22	└ 3.5BMF/3.5MF Bi-direction
With Outboard Bearing	└	23-24	
		25	└ Load of Outboard Bearing
Performance Curves	└	26-27	

Introduction of GRH Gear Motors

Gear motors from Guorui Hydraulics have a floating bushing feature with automatic axial clearance compensation. The bushings are made with special abrasion resistant material providing improved service life. Precisely machined gears ensure the excellent characteristics under low noise condition. Our cold extrusion motor bodies can endure pressure above 30 MPa. High strength cast iron front & rear covers also enhance our reliability. Our gear motors are widely used in the industrial, mobile, marine and aerospace industries.

GRH has 5 series of gear motors: group 1, 2, 2.5, 3 and 3.5. They can be divided into two types. One is the single direction gear motor, the other is the bi-direction gear motors. Normally the design of the single direction gear motor is similar to that of the single direction gear pump with some slight design differences. Therefore, every GRH gear motor has the corresponding single direction gear motors. When placing your order, please refer to the ordering code.

We now focus on the bi-direction gear motors. This motor has a different sealing structure to the single direction motor. The symmetrical sealing (refer to the following drawing) separating high pressure from low pressure thus allowing bi-direction operation. The oil from internal leakage returns to tank through the drain port. Normal case drain pressure is limited to 2 bar, but 5 bar is allowed for intermittent operation. High quality of the bushings, bearings and seals adds to the outstanding performance of GRH bi-direction gear motors.

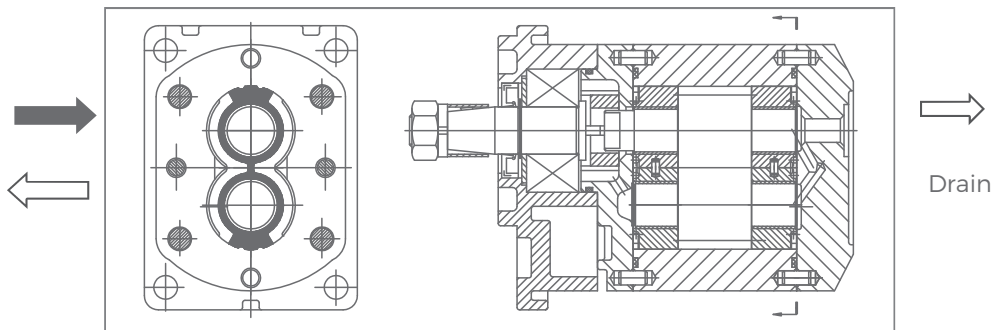

Characteristics

Direction of rotation: bi-direction and single-direction

Permissible ambient temperature range: min. -20°C - max. 60°C

Operating pressures: input side P1 max = refer above data; outlet side P2 max. 3 bar

Drain pressure: max. 2 bar, Short time: max. 5bar

Fluid temperature range: max. 90°C for NBR rotary shaft lip-type seal, 100°C for FKM rotary shaft lip-type seal

Viscosity range: min. 10mm²/s - max. 600mm²/s

Filtration

Recommended Viscosity range: $V = 30\text{-}45\text{mm}^2/\text{s}$

Recommended hydraulic fluids use: GB11118-94, L-HM46 or equate NFE-603/DIN51524 II-85

Characteristic curves refer to pages: page 26 to 28

Characteristics

Pressure Standard	$P \leq 2000\text{PSI}(14\text{MPa})$	$2000\text{PSI}(14\text{MPa}) < P < 3050\text{PSI}(21\text{MPa})$	$P \geq 3050\text{PSI}(21\text{MPa})$
NAS1638	10	9	8
ISO4406	19/16	18/15	17/14
Accuracy	$25\mu\text{m}$	$20\mu\text{m}$	$10\mu\text{m}$

All motor can be intergrated with relief valve, propotional valve, thermostatic valve.

Guidance for Use of the Curve

In most cases, with the data of torque output M at speed n , and to get the data of pressure difference Δp and the required Input flow, for example:

- ① $M = 40\text{ Nm}$; ② $n = 1000\text{ rpm}$; the intersection of ① and ② is the motor operating point with; ③ $\Delta p = 123\text{ bar}$;
- ④ $Q = 21.3\text{ l/min}$

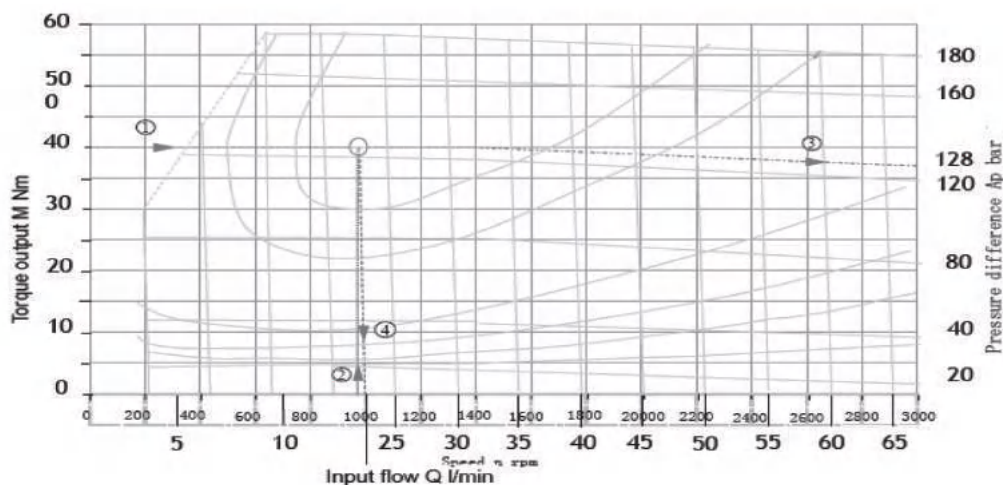



Specifications

Series	Displacement (ml/r)	Pressure (bar)			Speed (r/min)		Volumetric Efficiency (%)	Mechanical Efficiency (%)	Output Torque (N.m)
		Rated	Int	Peak	Max.	Min.			
1MF	1.1 - 5.1	200	230	250	4000	650	90	85	2.97 - 13.8
1MF	5.1 - 8.5	200	230	250	3600	650			13.8 - 23
2MF	4 - 8	200	250	280	4000	600	92	85	2.97 - 13.8
2MF	8 - 15	200	250	280	3500	600			10.8 - 40.6
2MF	15 - 20	200	250	280	3000	600			40.6 - 54.1
2MF	20 - 26	200	250	280	2500	500			54.1 - 70.3
2MF	26 - 30	180	210	250	2000	500			63.3 - 73.1
2.5MF	10 - 20	200	230	250	3600	500	92	85	27.1 - 54.1
2.5MF	20 - 30	200	230	250	3000	500			54.1 - 81.2
2.5MF	30 - 40	180	210	250	3000	400			73.1 - 97.4
2.8QMF	14.9-89.5	200	230	250	2500	600	92	86	40.8-245.1
3MF	22 - 43	200	230	250	3000	400	93	86	60.3 - 117.7
3MF	43 - 70	200	230	250	2500	400			117.7 - 191.7
3MF	70 - 89	200	230	250	2200	400			191.7 - 243.7
3.5QMF	24.99 - 124.96	200	230	250	2500	600	93	86	68.4-342.2
3.5MF	52 - 73	170	200	210	3600	500			121.1 - 169.9
3.5MF	73 - 100	150	165	180	3000	500			149.9 - 205.4
3.5MF	100 - 115	120	130	140	2500	500			164.3 - 188.9

Calculated Formulas

Displacement	Flow	Pressure	Speed	Power	Torque	Volumetric Efficiency	Mechanical Efficiency	Total Efficiency
cm ³ /r	l/min	bar	r/min	kW	N.m	90%	85%	80%
V	Q	Δp	n	P	M	η _v	η _m	η _t

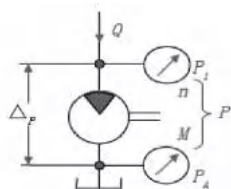

$$Q = V \cdot n \cdot 10^{-3} / \eta_v$$

$$M = \Delta p \cdot V \cdot \eta_m / 62.83$$

$$P = 2\pi \cdot n \cdot M / 60000$$

Ordering Code

2	A	M	F	8	F06	E007	R09	B	-BB	-O	-I	-F
a	b	c	d	e	f	g	h	i	j	k	l	m

Ⓐ 2=Group 2

Ⓑ Covers

A/Q=Cast iron cover
S=Cast aluminum cover
Omit=Aluminum cover

Ⓒ M=Gear motor

Ⓓ Continuous operate pressure

F=200bar

G=250bar

Ⓔ Motor displacement

4, 6, 8, 10, 12, 14, 16, 18, 20, 23, 25

Ⓕ Inlet/Outlet combination

F06=Inlet(Φ40/M8/Φ20) Outlet(Φ30/M6/Φ13)

F85=Inlet(Φ35/M6/Φ15) Outlet(Φ35/M6/Φ15)

F52=Inlet(Φ35/M6/Φ15) Outlet(Φ40/M6/Φ20)

L04=Inlet(G1/2) Outlet(G1/2)

L46=Inlet(G3/4) Outlet(G3/4)

L76=Inlet(1-5/8-12UN-2B) Outlet(7/8-14UNF-2B)

Ⓖ Drive shaft extension and flange combination

E002=1:8 taper key shaft M7×1

E007=1:8 taper key shaft M12×1.25

S013=SAE 16/32 9 tooth splined shaft

P021=5/8 flat key shaft

S011=SAE 16-32 11 tooth splined shaft

S014=SAE 16-32 10 tooth splined shaft

P022=3/4 flat key shaft

T003=1:5 taper key shaft M12×1.5

E013=20.22 taper key shaft M14×1.5

S015=SAE16/32 13 tooth splined shaft

Ⓗ Flange combination

R09=Europe rectangle flange

D09=SAE A flange two grooves

D20=SAE B flange

D10=SAE A flange

D23=6 hole flange

R25=Europe rectangle flange

Ⓘ Rotation direction

B=Bi-direction

L=CCW

R=CW

Ⓙ Inlet/Outlet position combination

BF=Back inlet and front outlet

BB=Back inlet and back outlet

BS=Back inlet and side outlet

SB=Side inlet and back outlet

SF=Side inlet and front outlet

SS=Side inlet and side outlet

Ⓚ Outboard bearing

O=Outboard bearing

Omit=Without outboard bearing

Ⓛ Mode of drain

I=Inner drain

Omit=Outside drain

Ⓜ Seals

F=FKM seal

Omit=NBR seal

1MFL69E002R001-B**

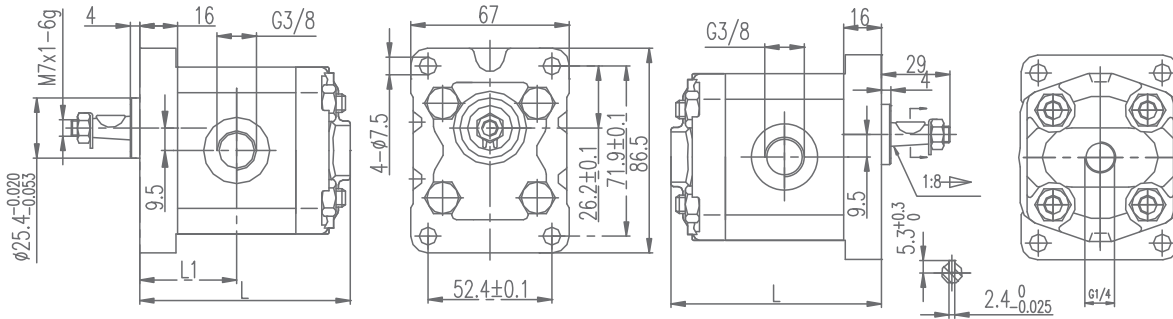

Displacement (ml/r)	1.1	1.6	2.1	2.7	3.2	3.7	4.2	4.8	5.8	6.5	8.0
L1	33	35	36	37	38	39	40	41	43	44	47
L	75	78	79	81	83	85	87	89	93	95	101

1AMFL**P006D02-B**

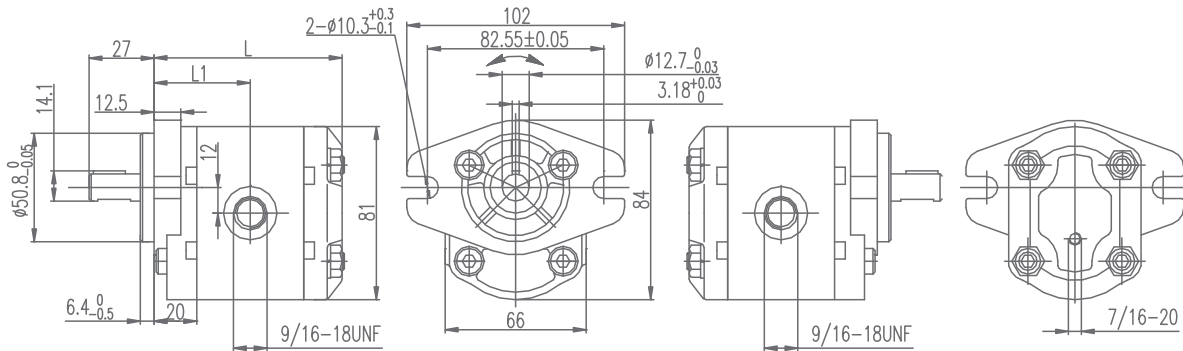

Displacement (ml/r)	1.3	2.0	2.7	3.4	4.1	5.1	6.1	6.5	7.0	7.5	8.5
L1	42	43	43	45	46	47.5	49	49.5	50	50.5	52
L	82	84	86	88	90	93	96	98	100	102	103

1DMF6.1LJ86P090E24B-BB

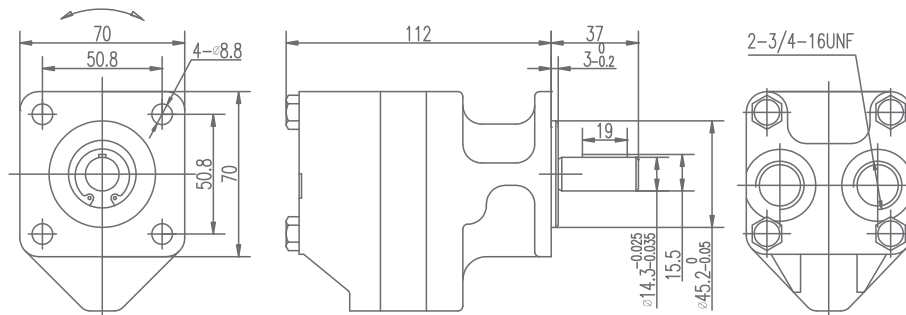

Displacement (ml/r)	Working Pressure (bar)	Max Speed (rpm)	Torque (Nm)	Direction
6.2	70	5000	5.78	Bi-direction

2MF**L04FP022D09-B-1

This motor is internal drain port structure. Two check valves guarantee its bi-directional function and have the oil of internal leakage return to inlet port. The function symbols are as follows:

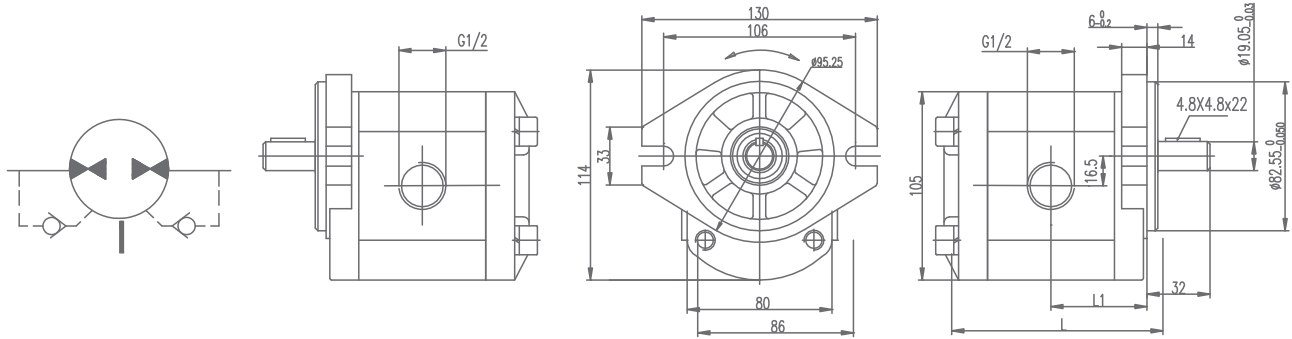

Displacement (ml/r)	4	6	8	10	12	14	16	18	20	23	25
L1	44	45	47	48	50	51	53	55	56	58	60
L	96	98	102	104	108	108	114	117	120	123	128

2MF**F**S013D09-R-V

The motor is with the relief valve of which the highest working pressure is same as that of the motor inlet port. The function symbols are as follows:

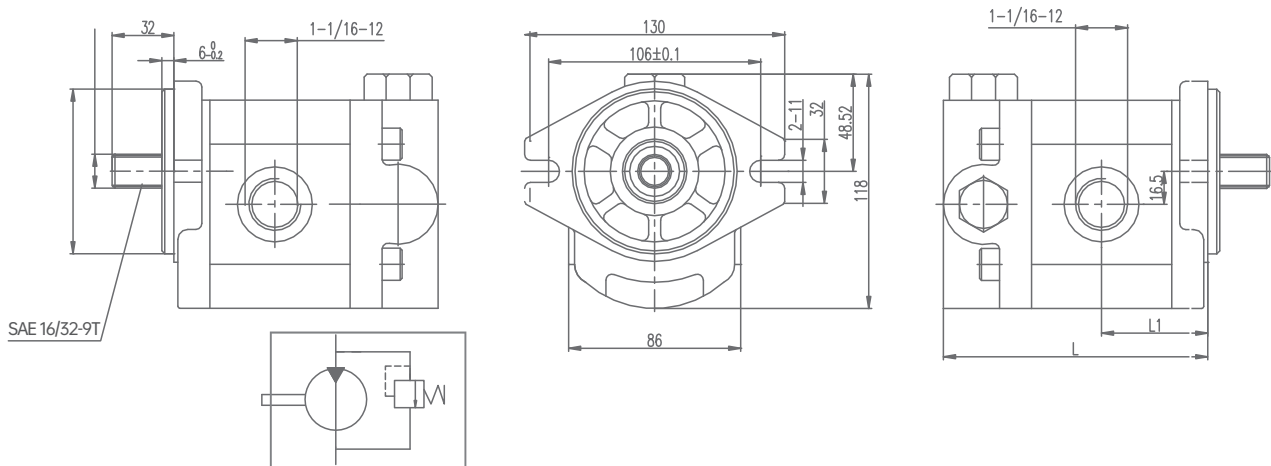

Displacement (ml/r)	4	6	8	10	12	14	16	18	20	23	25
L1	39	40	41	43	44	46	48	49	51	54	57
L	111	112	115	118	120	125	128	132	137	139	141



2SMGxxLJ36S031D49-03JS

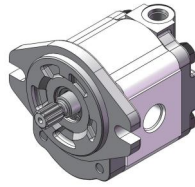

Series	Displacement (ml/r)	Pressure (bar)			Speed (r/min)		
		P1(Cont.)	P2(Int.)	P3(Peak)	Rated	Max.	Min.
2SMG	6	250	260	280	2000	700	4000
2SMG	8.4	250	260	280	2000	700	4000
2SMG	10.8	250	260	280	2000	700	4000
2SMG	12.3	250	260	280	2000	700	4000
2SMG	16.8	250	260	280	2000	700	4000

2SMGxxLJ36S031D49-03JS

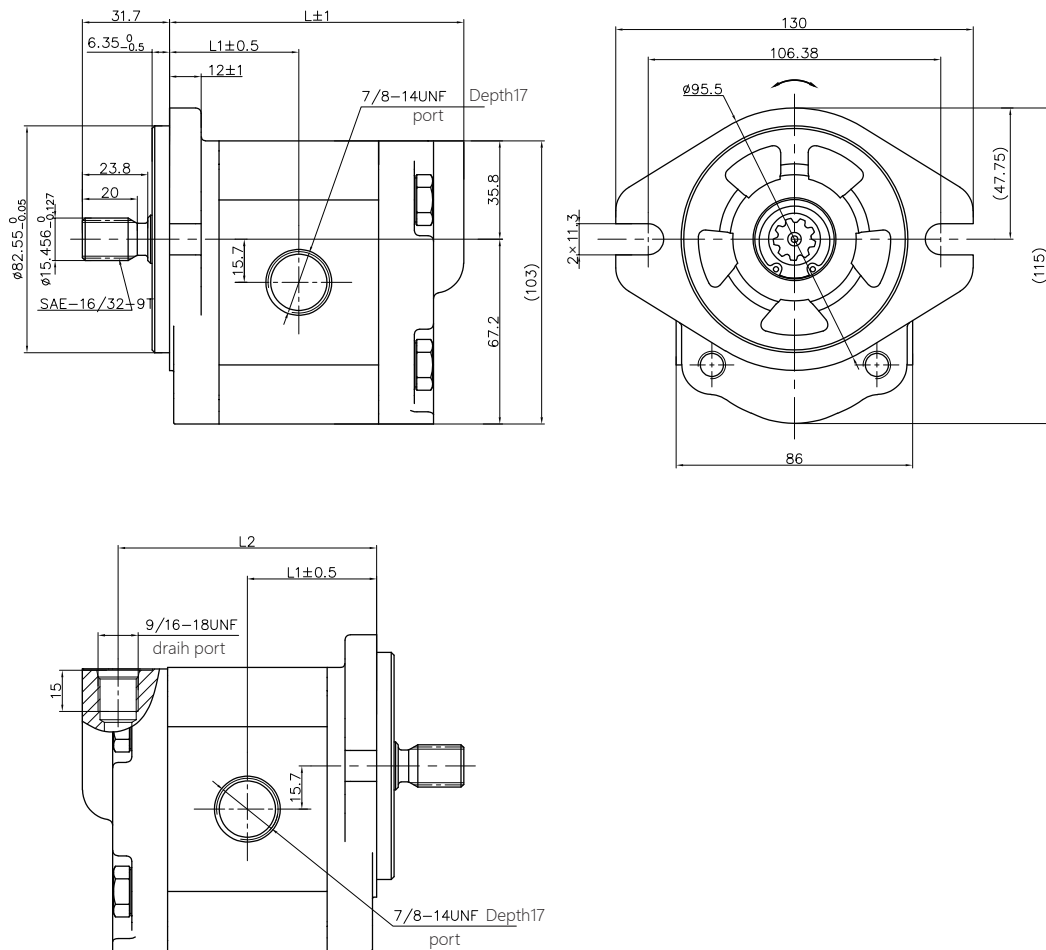



2.8QMFxxSSxxBBxxS026D43-B

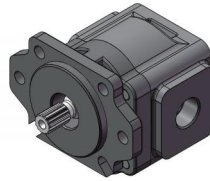

Series	Displacement (ml/r)	Pressure (bar)			Speed (r/min)		
		P1 (Cont.)	P2 (Int.)	P3 (Peak)	Rated	Max.	Min.
2.8QMF	30	200	230	250	1200	350	2500
2.8QMF	42	200	230	250	1200	350	2500
2.8QMF	51	200	230	250	1200	350	2500
2.8QMF	57	200	230	250	1200	350	2500
2.8QMF	64	200	230	250	1200	350	2500

2.8QMFxxSSxxBBxxS026D43-B

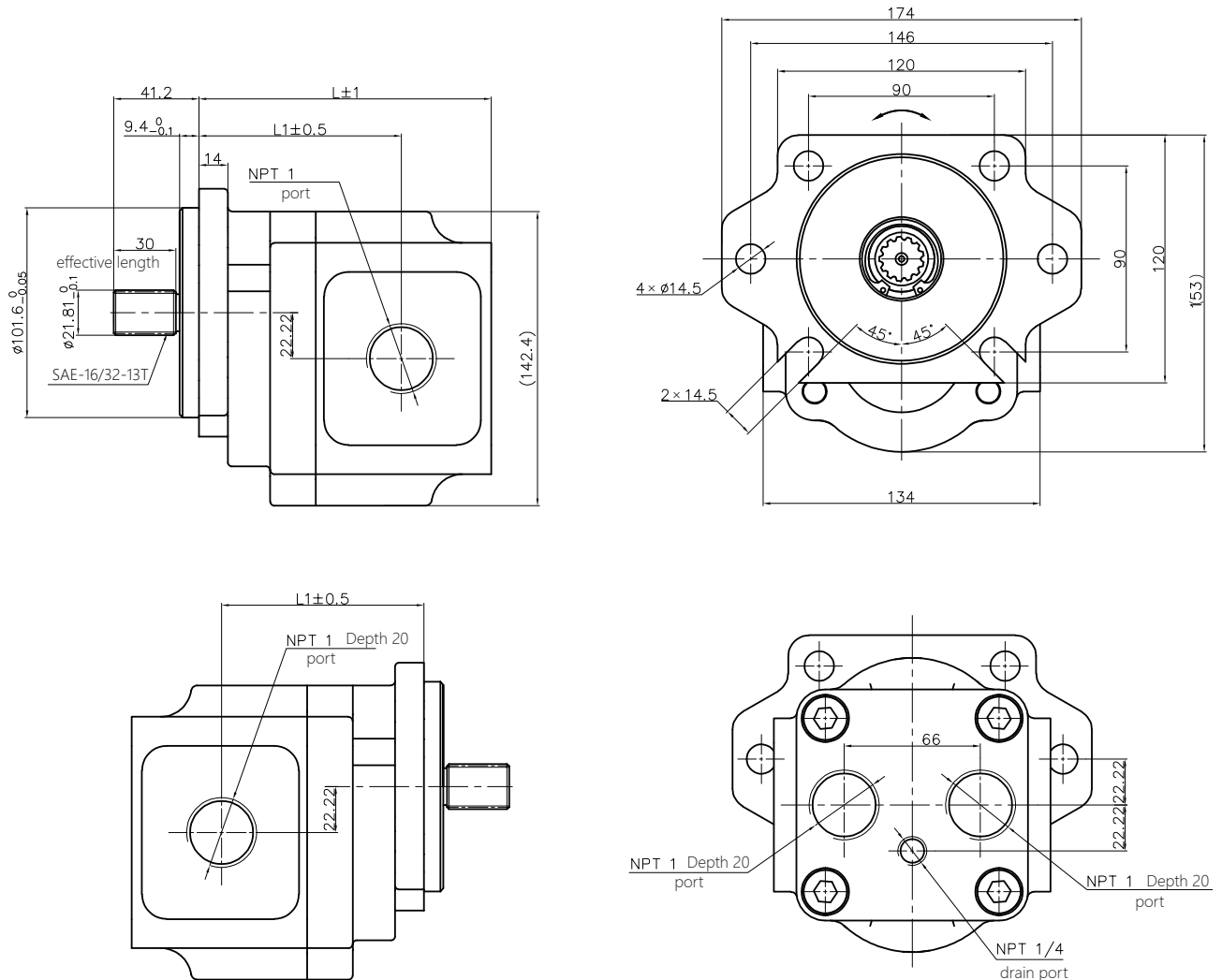

3.5QMFxxSSxxBBxxS026D44-B

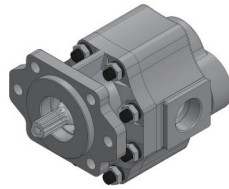

Series	Displacement (ml/r)	Pressure (bar)			Speed (r/min)		
		P1(Cont.)	P2(Int.)	P3(Peak)	Rated	Max.	Min.
3.5QMF	72	160	180	210	1000	350	2500
3.5QMF	87	160	180	210	1000	350	2500
3.5QMF	95	160	180	210	1000	350	2500
3.5QMF	102	160	180	210	1000	350	2500

3.5QMFxxSSxxBBxxS026D44-B

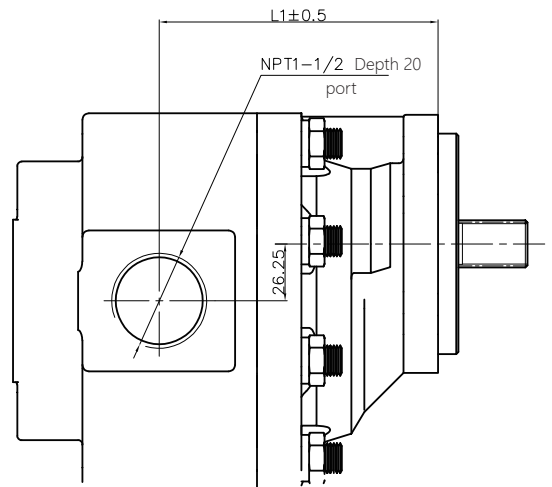
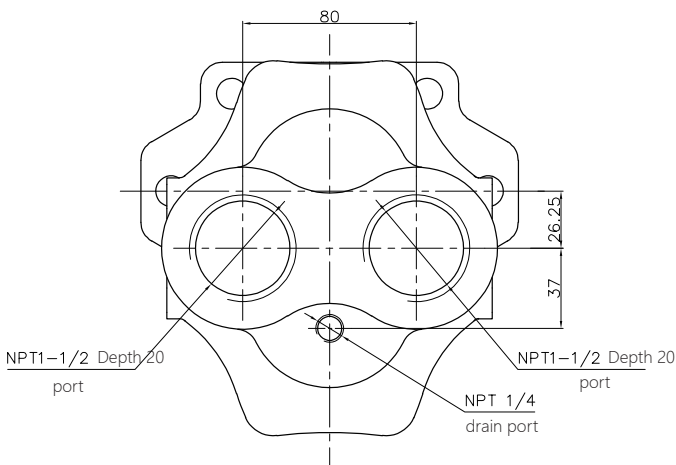
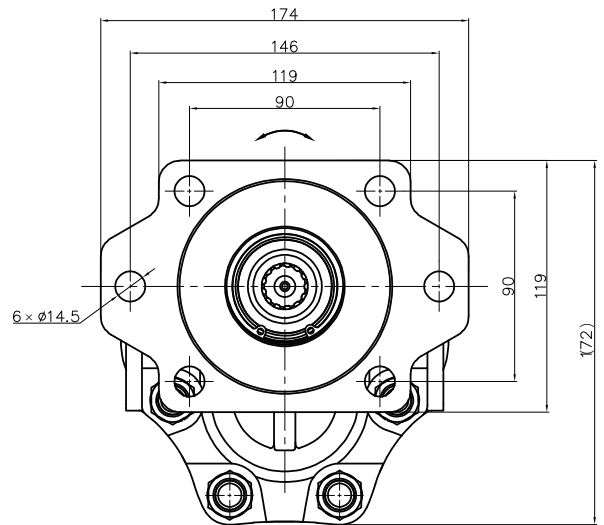
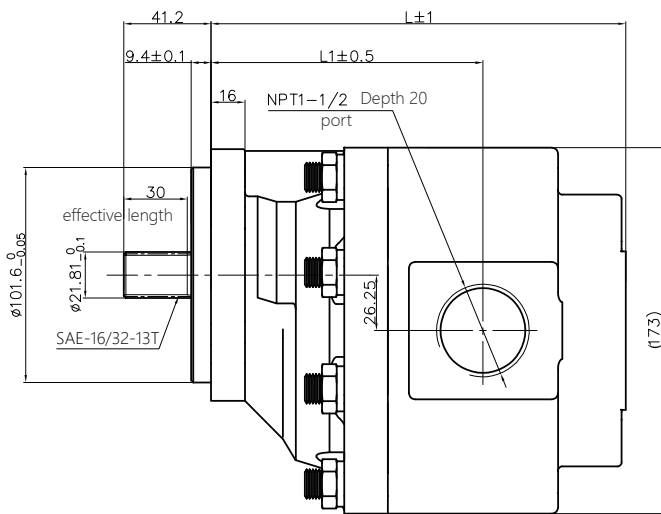



3.5BMFF108F102S13-B**

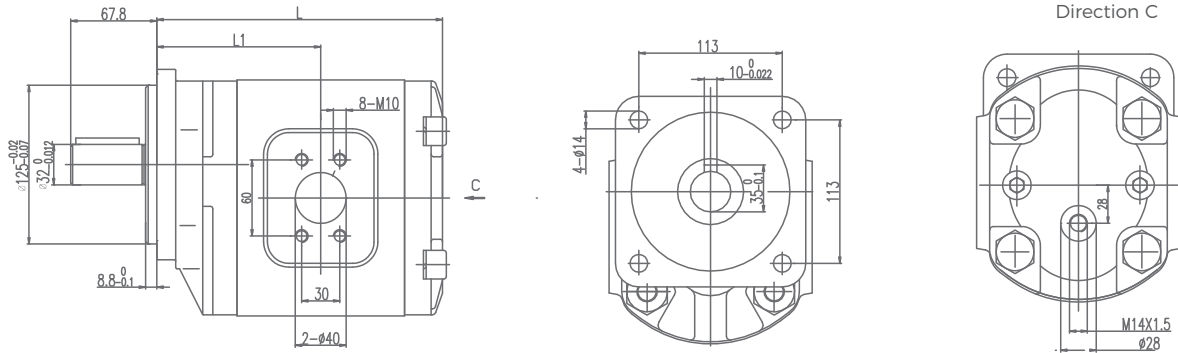

Displacement (ml/r)	63	80	100
L1	119	125	132
L	215	221	228

3.5MFL**S84D14-B**

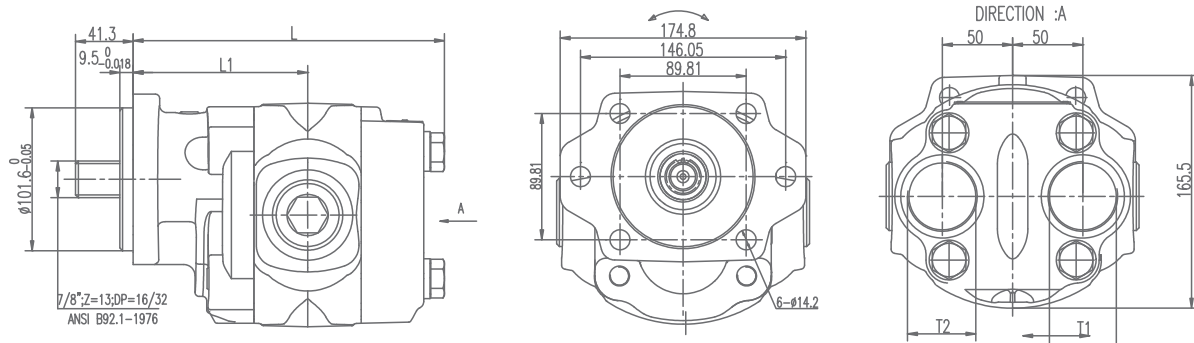

Displacement (ml/r)	52	63	73	85	93	104	115
L1	181	188	194	200	207	213	219
L	207	216	225	235	244	255	264

3.5MFL**S95D17-B**

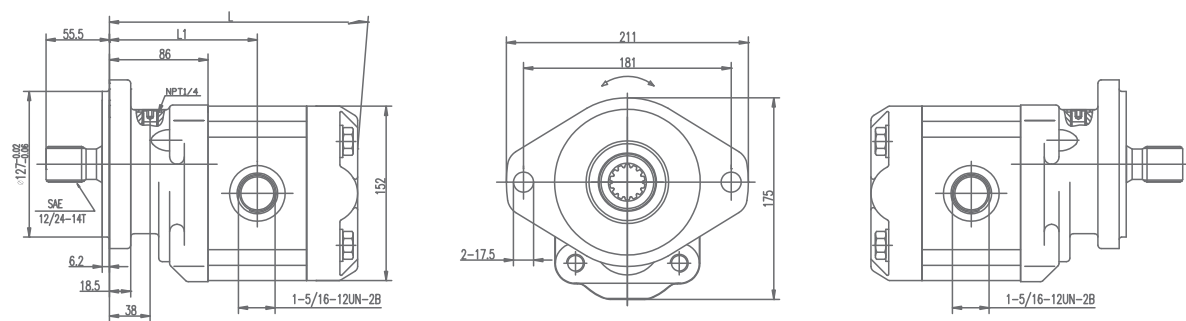

Displacement (ml/r)	52	63	73	85	93	104	115
L1	181	188	194	200	207	213	219
L	207	216	225	235	244	255	264

Outboard Bearing 2MF**L**F63D10-B-O

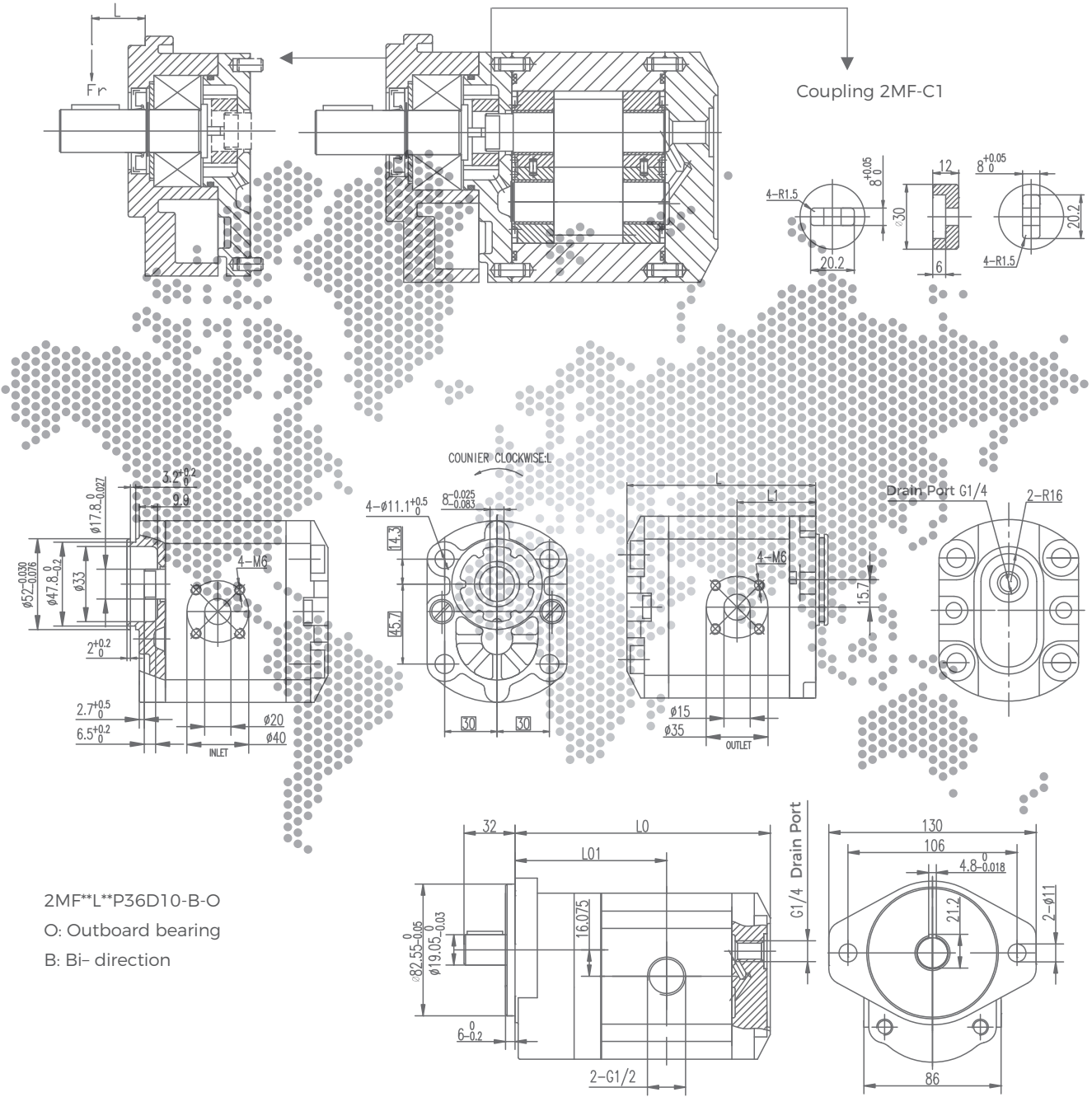

2MF**L**P36D10-B-O
 O: Outboard bearing
 B: Bi- direction

Displacement (ml/r)	4	6	8	10	12	14	16	18	20	23	25
Shanghai Ryan Hydraulic Fluid Power Co., Ltd	75	81	82	86	86	80	88	90	91	94	95
Add. Room 2201-2202, 1717 North Sichuan Road, Hongkou Shanghai, China	40	41	43	44	44	46	48	49	51	54	54
P.C. 200080	90	91	94	96.5	98.5	103.5	107	111	116	118	118
Tel. +86-21-5662 6882											

Mail. sales@ryanhydraulic.com



Load of Outboard Bearing

FO=0 N

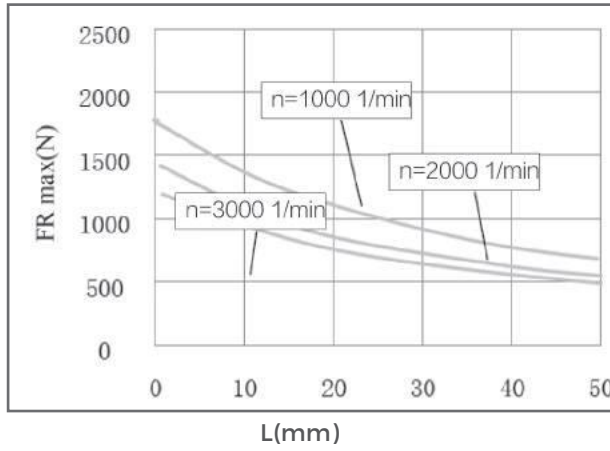

FO=200 N

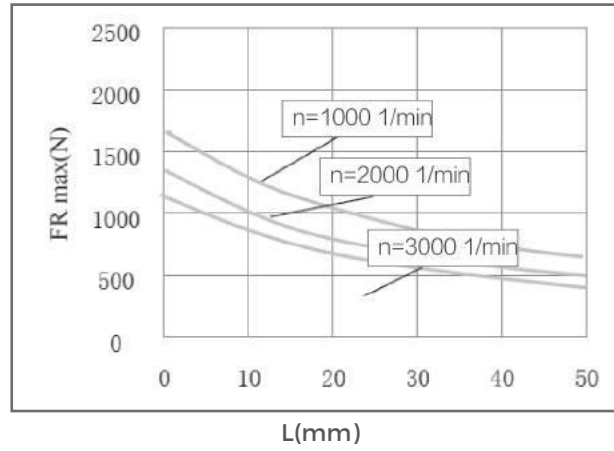

FO=400 N

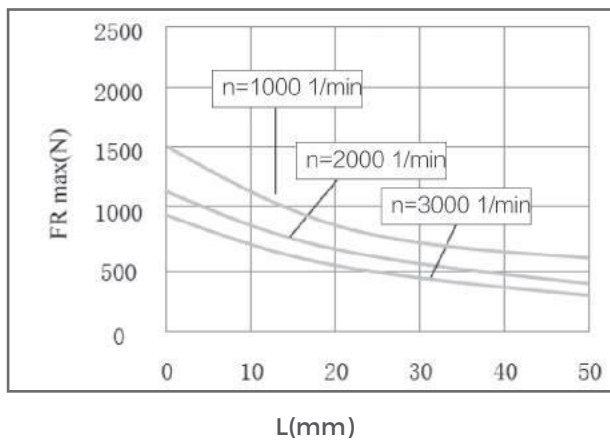

FO=600 N

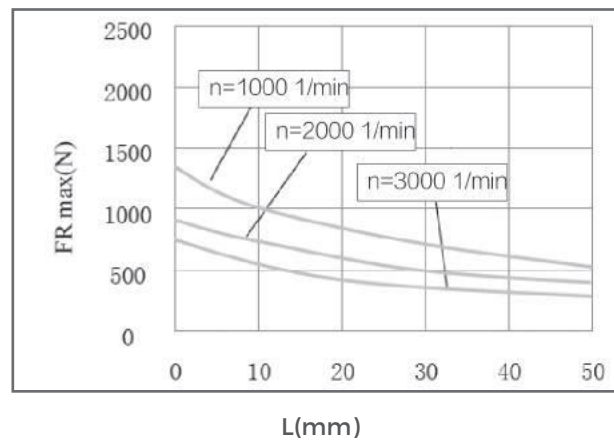

FO=800 N

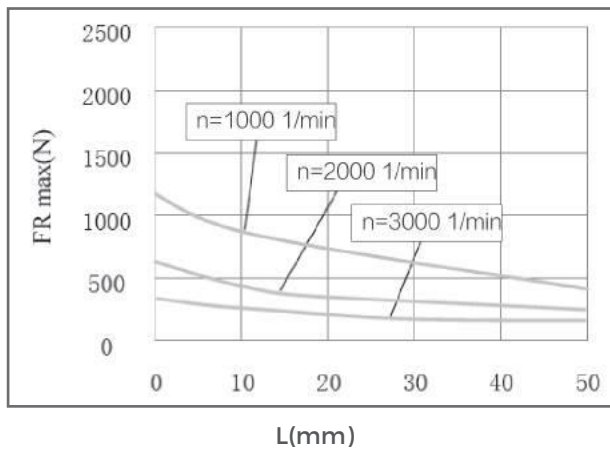

FO=900 N

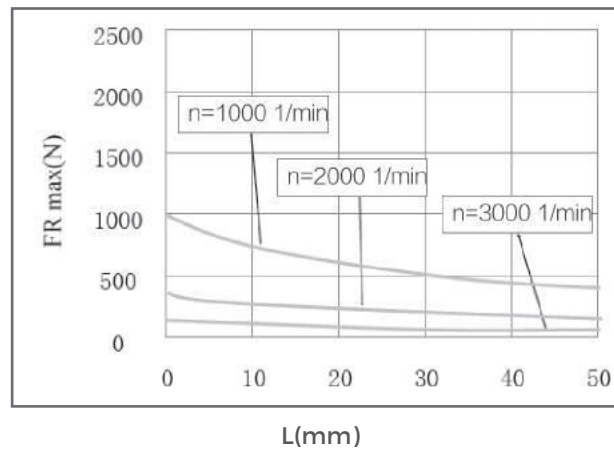

2MF6 Performance Curves

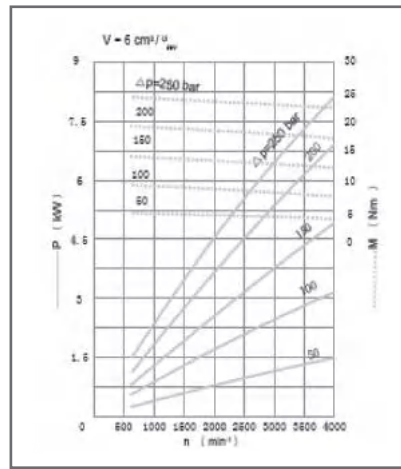
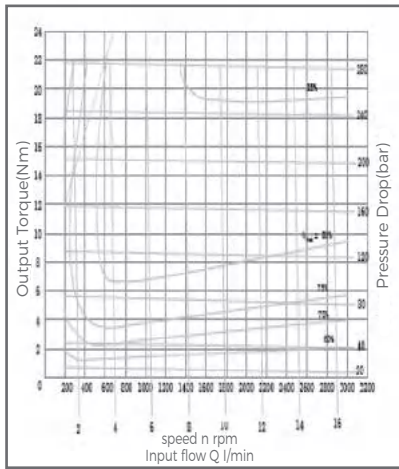

2MF8 Performance Curves

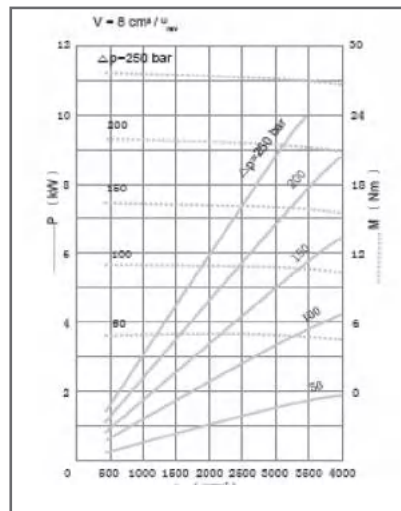
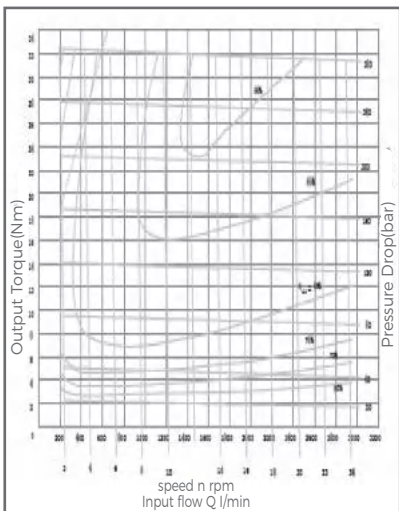

2MF11 Performance Curves

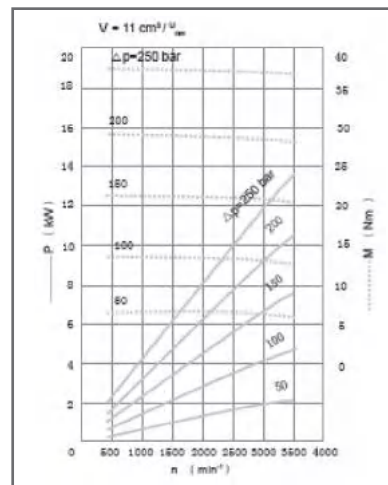
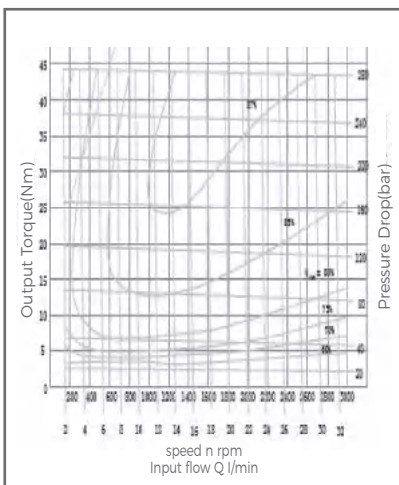

2MF6 Performance Curves

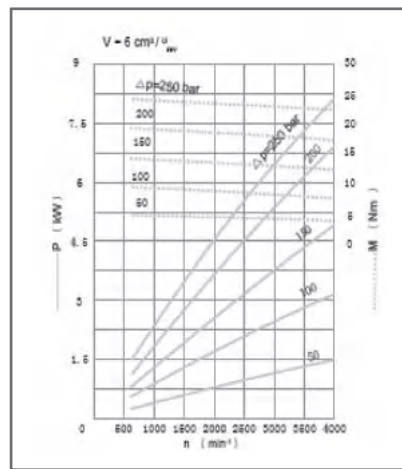
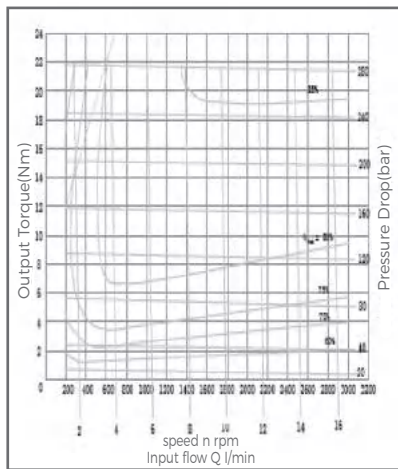

2MF8 Performance Curves

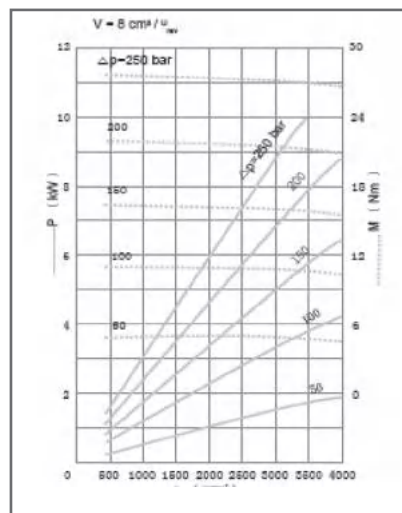
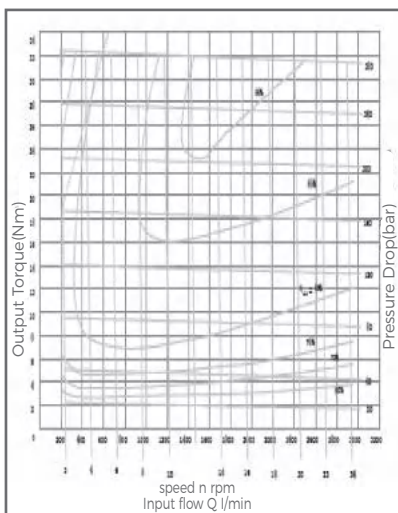

2MF11 Performance Curves

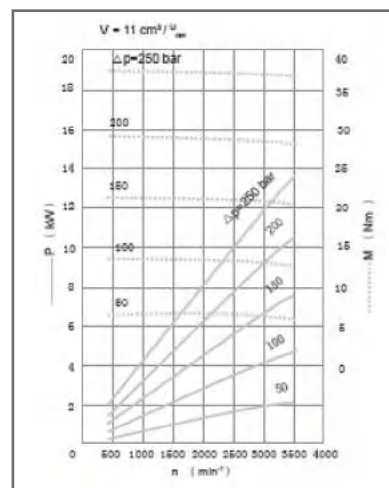
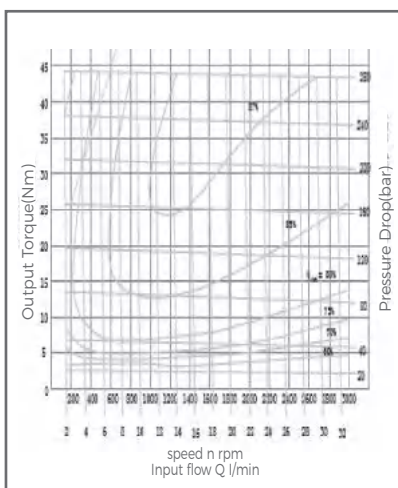



Shanghai Ryan Hydraulic Fluid Power Co., Ltd

Add. Room 2201-2202, 1717 North Sichuan Road,
Hongkou Shanghai, China
P.C. 200080
Tel. +86-21-5662 6882
Mail. sales@ryanhydraulic.com

