

Technical Manual

# Electric Control System

Controller / HMI + PLC / Joystick / Bus button





## **RYAN HYDRAULICS**

Keep the concept seeking excellence.

RYAN try our best to create more value for you with products and service.

# RYAN Hydraulics

## About RYAN

RYAN's manufacturing base was established in 1986, with quality hydraulic components and solutions to hydraulic system in the applications of engineering machinery, mobile industries, agricultural machinery, aviation, mining, and other fields. Main products include gear pump, gear motor, flow divider, orbital motor, loadsensing proportional valve, monoblock valve, sectional valve, manifold assembly and hydraulic power unit as well.

## Long-term Development Strategy

Reducing emissions by new energy is one of RYAN's long-term strategies. RYAN will be providing innovative technologies, products, and services for the global development of new energy, moving towards a century development strategy, and writing a century-new chapter in the hydraulic field.



### Innovation leads the future

Through a few decades of development, RYAN's manufacturing base has built an intelligent manufacturing factory, gathering international R&D talents, accumulating rich R&D and manufacturing experience, possessing independent intellectual property rights, continuously providing customers with new products and technologies, and creating value for all of the customers.



## Catalogue

### Controller

GHC-12A series mobile controller	05-12
Cylinder speed control	08
Motor speed control	09
Load-sensitive pump	10
Position control	11
Pressure control	12
HHC-35A controller	13-15
HHC-26C controller	16-18
HHC-24A sensing controller	19-21

### HMI + PLC

HHDC - 40I The display with controller	22-25
HHDC - 70L The display with controller	26-30

### Joystick/ switch

HHH-26B Smart shift joystick	31-33
HHS-6A Bus bottom switch	34-36

## ■ Precautions for electric control products

### 1. Electrical

- ⚠ In order to prevent electromagnetic interference damage, the housing must be well grounded, such as a ground connection to the moving vehicle.
- ⚠ In order to ensure stable operation, all the input and output ports must be connected to the ground provided by the module itself.
- ⚠ In order to protect the whole system (line and controller), a fuse must be installed to protect the product power input end.
- ⚠ Can be configured as a port of output or input point, if configured as an input connection, when the controller power off, the external input must also be powered off, otherwise the external input will cause reverse power supply to the controller, when the controller needs large current for external output control, it will cause damage to the controller.

### 2. Install

1. The installation direction should be made as far as possible at the outlet of the connector connection line downward. The heat generated inside the product is dissipated through the housing, and the installation should ensure that there is a certain heat dissipation space around the product.
2. There is no serviceable part inside the product, so it is not recommended to open the product shell. If the product fails, it shall be repaired by the manufacturer. Products that disassemble the shell without the permission of the manufacturer will lose the warranty service.

## ■ Electro-hydraulic proportional control topology map

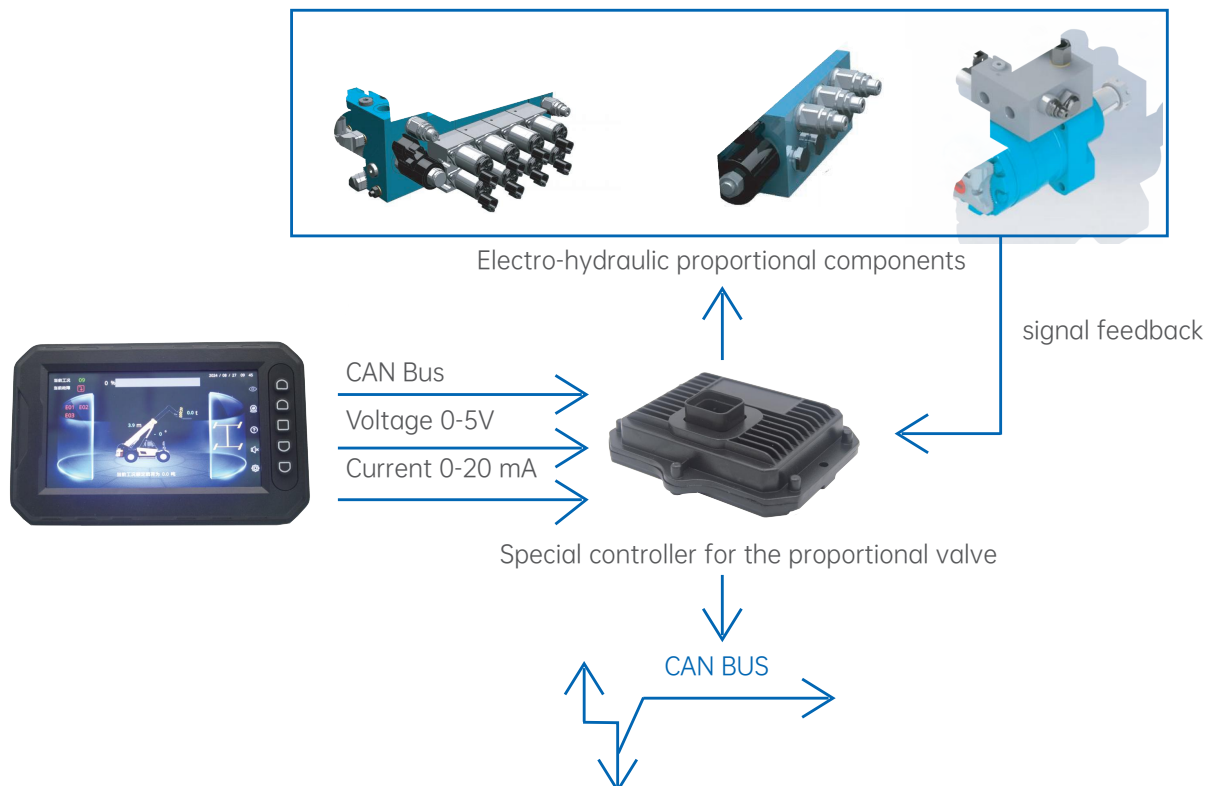



## GHC-12A Series Mobile Controller

### Application

- GHC-12A control module is an electro-hydraulic proportional controller suitable for various electro-hydraulic proportional valves and solenoid switching valves. Both superior performance and super high cost performance.
- For mobile machinery and industrial hydraulic equipment. Including but is not limited to the following fields: construction machinery, agriculture, forestry, construction, marine engineering, earthwork and material handling, etc.
- GHC-12A controller and proportional cartridge valve can achieve optimal pressure, flow and position control, and meet the application requirements with high repetition accuracy and high reliable solutions.



### Characteristic

#### ■ CAN Open Communication Function

- Programmable controller with CAN communication function.
- Can be used as the node of the CAN bus distributed control system.
- Through the CAN bus communication, the sensor feedback signal can be configured as the input signal.
- The input, output and feedback signals can be fed back to the upper computer or display through the CAN bus.

#### ■ The Quick Settings Page

- Set up the GHC-12A controller using the upper computer software.
  - In the typical pressure and flow control, a fast and reliable solution can be achieved only by selecting and setting the relevant parameters in the predefined interface of the upper computer.
  - Open loop control, can customize slope rate and start point.
  - Closed-loop control, customized PID parameters.
- Can be easily installed in a suitable position: can be easily connected with the pump and the motor and the integrated valve block, can also be installed in the control cabinet and cab.



### LED Signal Light

Disp.	Operation Modes	State		Description
		Green light	Red light	
1	Normal working mode			Green light is always bright
2	Low pressure mode			Red light is 500 mS on and 500 mS off
3	High pressure mode			Red light is often on
4	Bus working mode			Green light is 125 mS on for 2 times and off for 500 mS
5	Bus timeout			Red light is 125 mS on for 2 times and off for 500 mS
6	Output short circuit			Red light is often on
7	Output open			Red light is 125 mS on 3 times and off 500 mS
8	Illegal or excessive command			Red light is 500 mS on and off



## Technical Parameter

Function	Parameter		
Processor	32 bits, at 168 MHz		
Working voltage	9V~32V		
Continuous working current	3A		
No-load current	30mA@24V		
Mechanical size (L×W×H mm)	110mm×80mm×30mm		
Install	2 mounting holes fixed (ø4.5 mm)		
Levels of protection	IP67		
I/O port	Input 2 channels and output 2 channel		
Supporting electrical connection	MX23A12SF1 Plug + MX23A12XF1 sleeve + M23S05K351 terminal		
<b>Communication</b>			
Communication description of CAN interface	11 CAN interface, supporting CAN2.0B, CANOPEN. 10 Kbits / s ~ 1 Mbits / s (default setting: 250 Kbits / s)		
<b>Incoming signal</b>			
Standard input signal	GHC-12A (double input AI01 / AI02) 0-5 Vdc, 0-10 Vdc, 4-20 mA (Software configuration of input signal type)		
Signal entering range	Voltage input: 0-5V, 0-10V. Current input mode: 4-20 mA. Allowable input current: + 22 mA (input impedance Z≈249Ω). Physical damage may be caused when the signal voltage exceeds 15v or the current exceeds 50 mA.		
<b>Output signal</b>			
PWM output	0-2.25A Peak-40°C ~ + 85°C single channel persisted		
Current regulation	± 1 mA (if greater than 40 mA)		
PWM frequency	33Hz-5KHz		
Vibration frequency	0Hz-500Hz		
Vibration amplitude	The 0-25% PWM cycle		
Diagnostic signal	Open circuit short circuit diagnosis		
Slope time	And 0 – 60s, in 1-ms increments		
Reference end output	5 Vdc, (load current 200 mA)		
<b>Environmental suitability</b>			
Working temperature	-40°Cto+85°C	vibrate	33.3 Hz6.8g Peak(Spec:S-367 Section11.0)
Storage temperature	-60°Cto+120°C	Impact	49g Peak (Spec: S-367 Section 12.0)
EMC	《GB/T17626.2》 《GB/T17626.3》 《GB/T17626.4》 《GB/T17626.5》 《GB/T17626.6》 《GB/T17618》		



## Pin Wiring

Pin	Definition of the GHC-12A pins
1	POWER+
2	CAN-L
3	CAN-H
4	PWM1
5	Ground (input / output / reference voltage)
6	PWM2
7	Ground (input / output / reference voltage)
8	The+5V reference voltage
9	Enable
10	Signal input 1
11	Signal input 2
12	Power Supply Ground

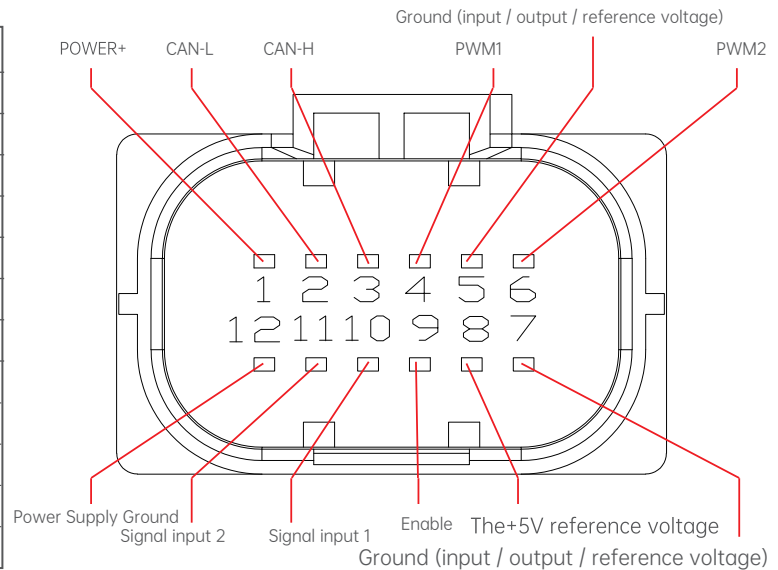

### Wiring notes

- 1) For good grounding, isolate pin 12 (power supply ground) and pin 7 and 5 (input / output / reference voltage ground)
- 2) According to CAN communication application standards, cables use twisted pair or shielded twisted pair
- 3) Ensure that the CAN Bus terminal resistance is configured
- 4) Ensure that the wiring harness minimizes electromagnetic interference between signal cables
- 5) Isolate the high-voltage AC cable and the DC signal and power cable
- 6) Ensure that all cables are not short-connected and disconnected
- 7) Ensure the safety of useless cables and pins, and do not short-connect them
- 8) If there is a battery charging equipment during the installation, please isolate the controller
- 9) Observe health and safety regulations during operation and protect site personnel
- 10) Wiring operation after power-off

### Installation Mode and Dimensions

- Standard connection mode
- Expandable installation method

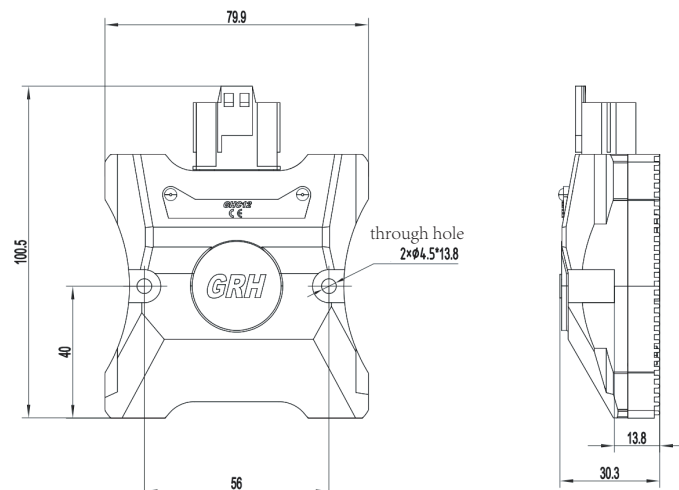

## Application Examples

Typical application:  
oil cylinder speed control

- A proportional electromagnet can be controlled  
It can also control the two proportional electro magnets simultaneously

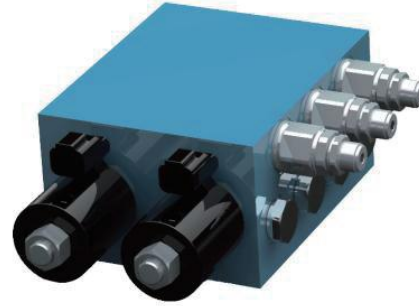

## Schematic Diagram

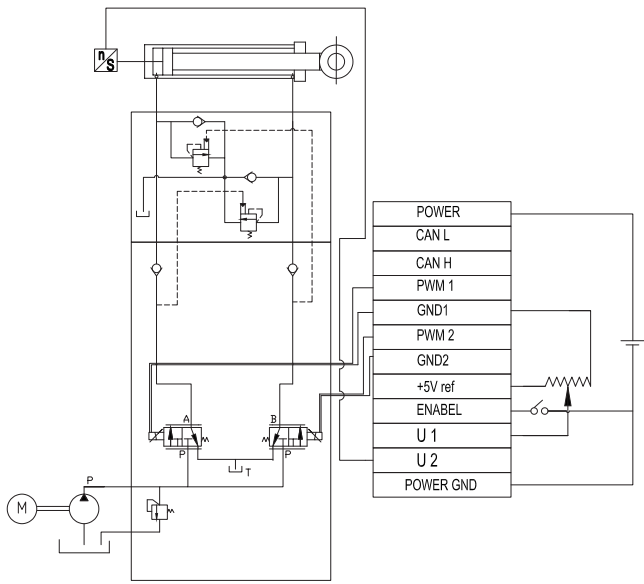

Speed control 1

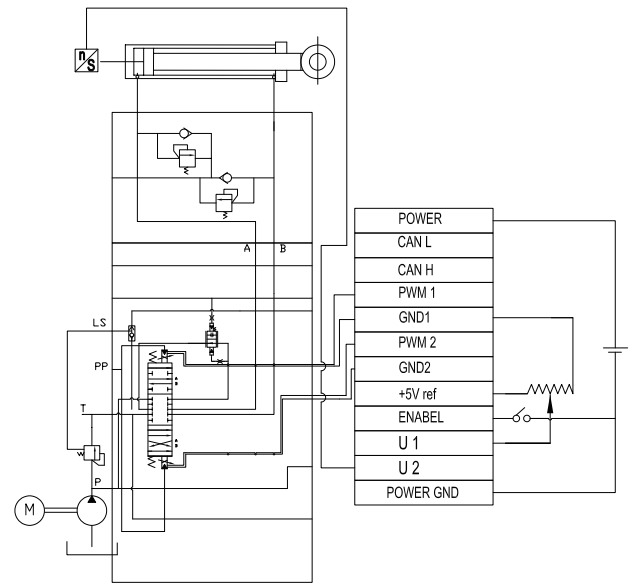

Speed control 2

## Equipment Applications





## Typical Application: Motor (fan) Speed Control

- Programmable control, the fan speed is relatively independent of the engine speed
- Precise control of the coolant temperature by the sensor
- The overall size is small and can be arranged flexibly
- Reduce fuel consumption, exhaust emissions, and low noise
- The inversion function enables the fan to automatically clean the radiator

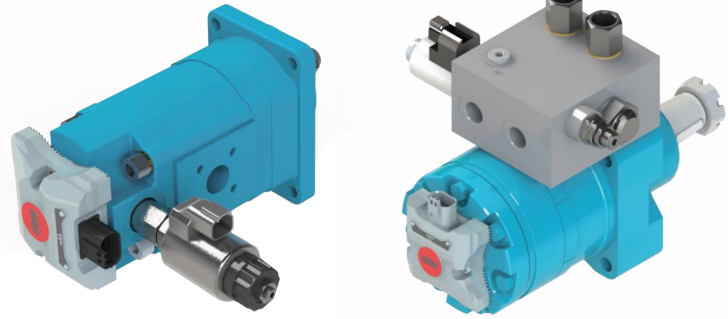

## Schematic Diagram

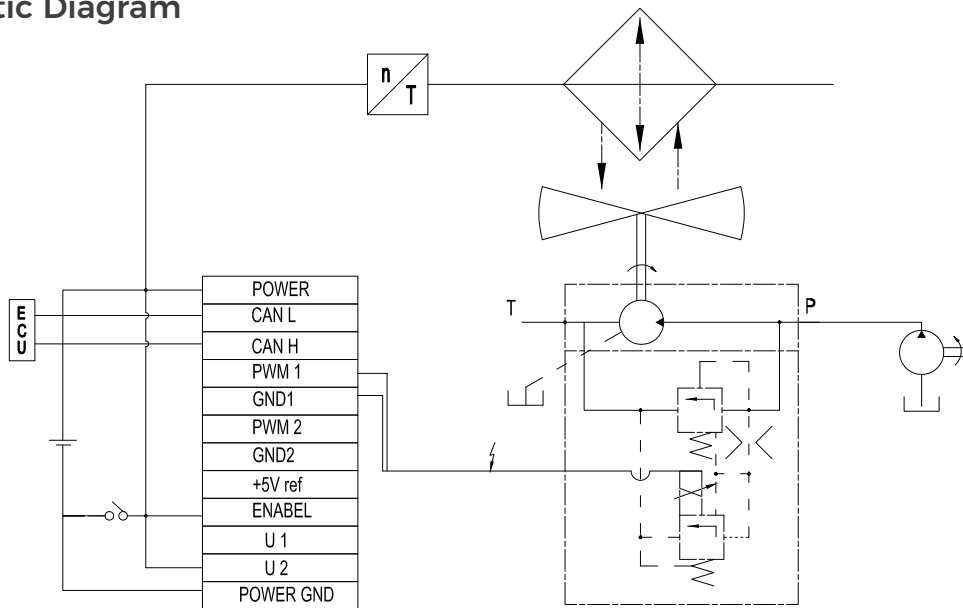

## Equipment Applications



## Typical Application: Load-sensitive pump

- Timely sense the outlet pressure and load pressure of the pump, and adjust the output flow of the pump
- Electronic controller, sensor and pump (variable pump or quantitative pump) together constitute an intelligent solution, through electronic control to ensure the system timely response and energy efficiency saving
- The current used liquid control load sensitive flow system can be easily upgraded to the electronic control hydraulic load sensitive system

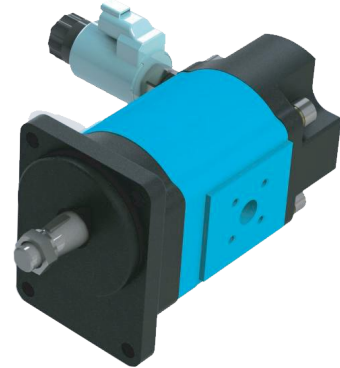

## Schematic Diagram

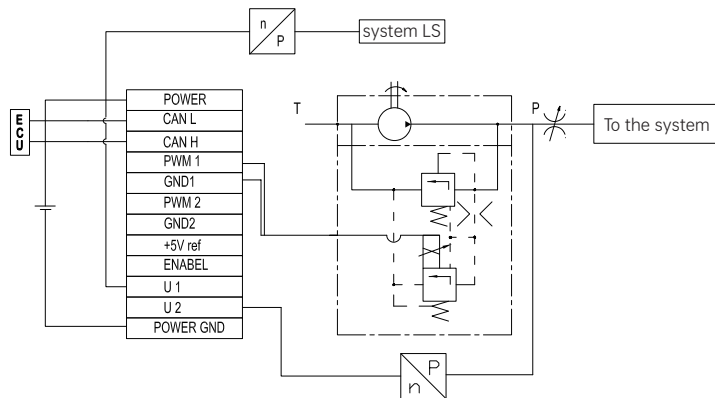

Load-sensitive gear pump

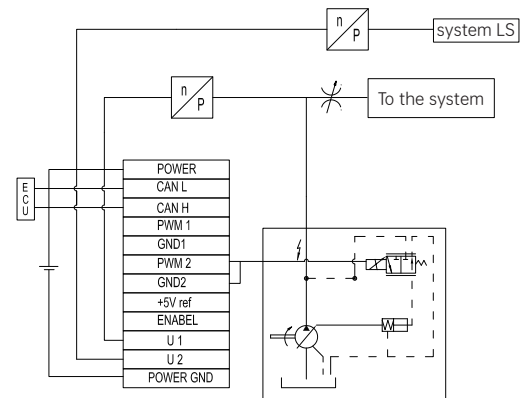

Load-sensitive variable displacement pump

## Equipment Applications





## Typical Application: Position control-large-horsepower tractor elevator

- Specifically designed for high-horsepower tractors
- Proportion elevator (plough depth position control)+ multiple hydraulic control proportional valve
- Electronic controlled lifting valve set for pear depth position control (Front pressure compensation), can be provided by split or integrated with the triple valve
- Flow of 20-100 L/min is optional

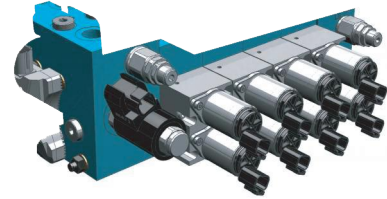

## Schematic Diagram

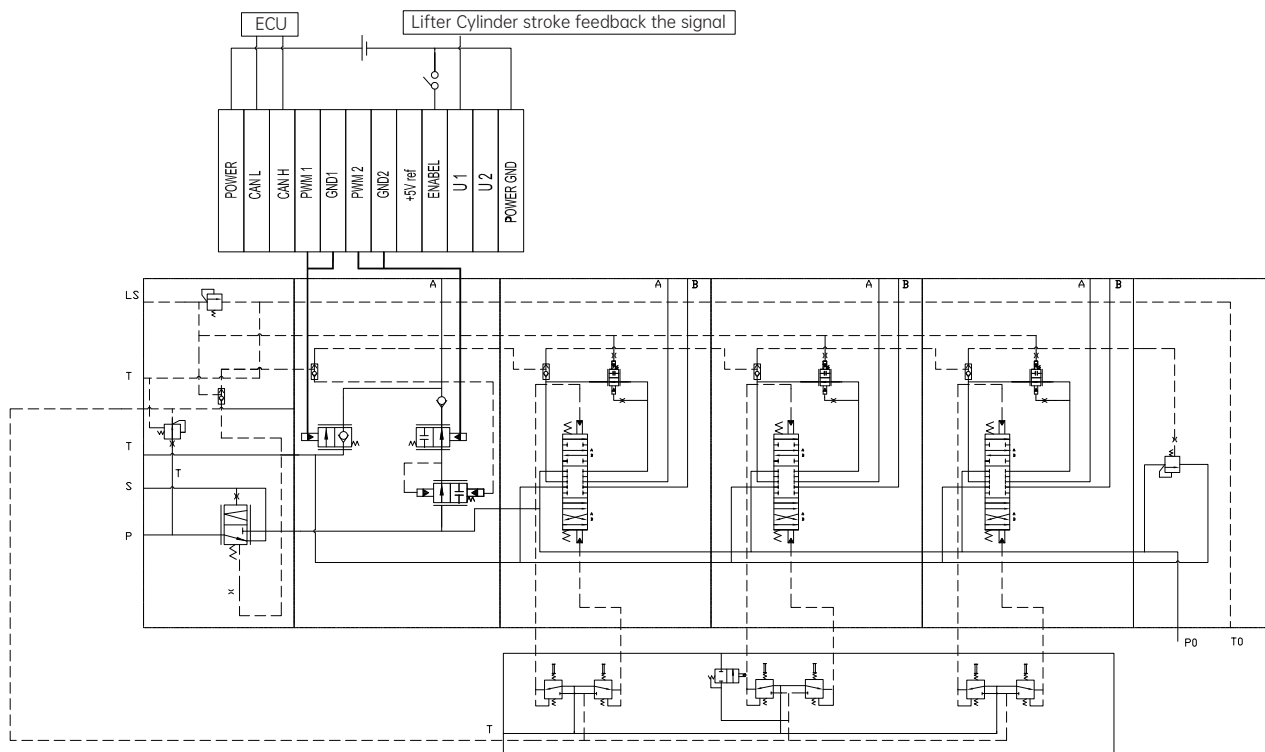

## Equipment Applications

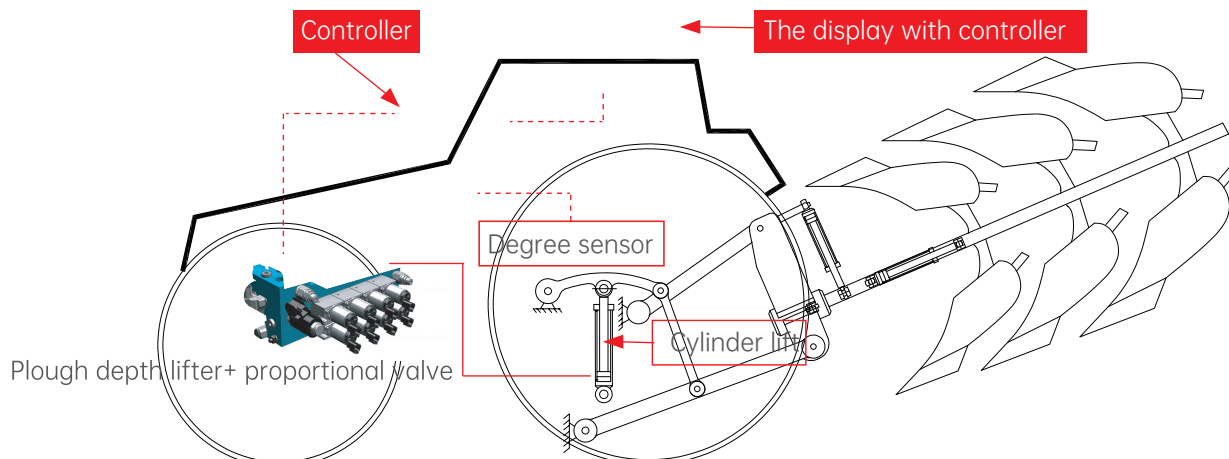

## Typical Application: Pressure control

- The controller, sensor and electric proportional valve are combined for stage pressure control as needed

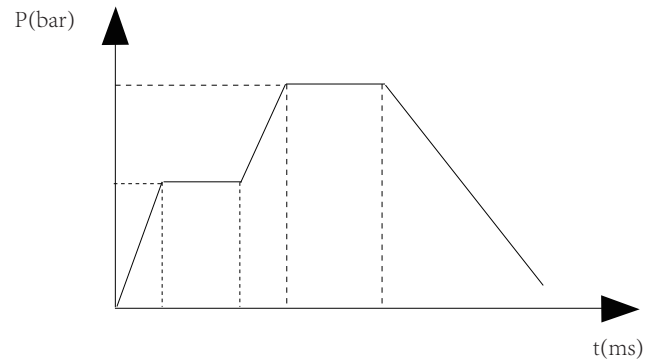

## Schematic Diagram

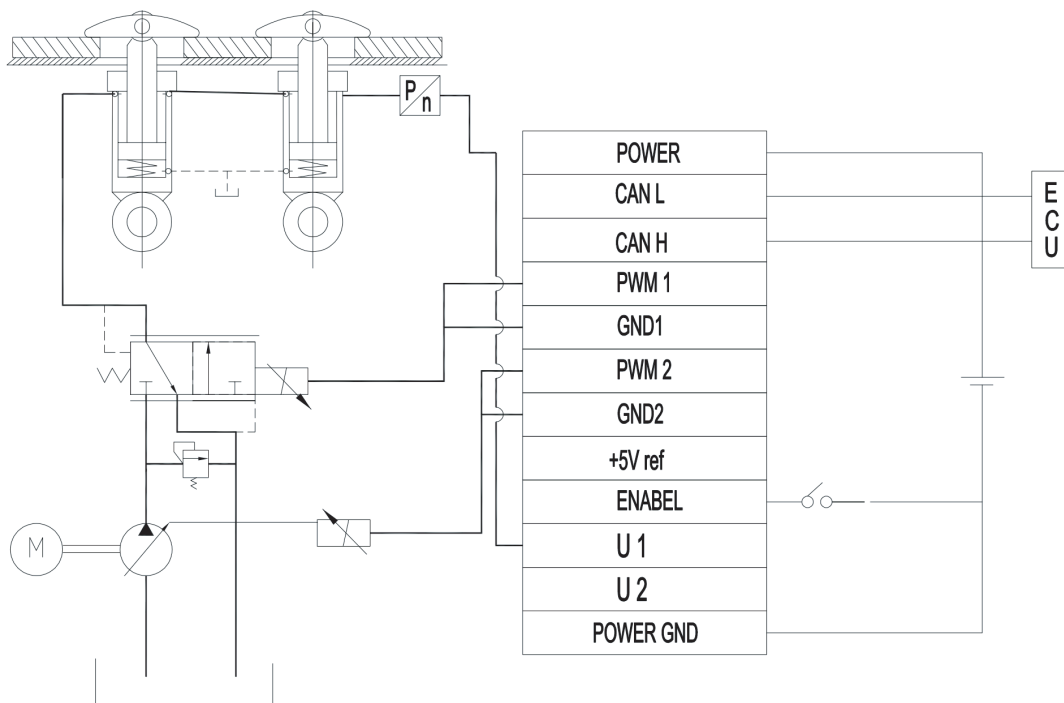



## HHC-35A Controller

### Description

HHC-35A is a powerful general-purpose controller product specially designed and developed for the construction machinery industry.

It has a complex port multiplexing function.

The high computing speed control chip provides the necessary computing and processing power. The product provides 27-channel multi-type reuse input port, 16-channel power output port, 1-channel sensor reference power supply, and 1-channel CAN 2.0 communication interface. Adapt to all kinds of harsh engineering application environment.



### Characteristic

- CAN Bus interface
- Strong and reliable metal housing, good heat dissipation performance, IP67 protection grade
- IO function (software setting)
- Direct drive of the hydraulic valve

### Technical Parameter

Function	Parameter
Processor	32 bits, 168MHz
Program Space (FLASH)	512KB
Data Space (RAM)	192KB
Power-down save data space (FRAM)	512B
Working voltage	9V~32V
Continuous working current	16A@24V
No-load current	50mA@24V
Mechanical size (L×W×Hmm)	165×150×46.5mm
Install	Fix (ø5.5mm) with M5X16 inner hexagon bolts
Linkage	Cover 776164-1; terminal: 770520-1; sealing plug: 770678-1
Weight. 0.5 Kg	588g
Working temperature	-40 °C~ +85°C
Storage temperature	-40 °C~ +125°C
Levels of protection	IP67
Communication description of CAN interface	1 CAN interface, supporting CAN2.0B. 10 Kbits / s ~ 1 Mbits / s (default setting: 250 Kbits / s)
Input	Max 27 road
output	Max 16 road



## Port Definition

Port	Function	Remark		
1	VS	Power supply input, voltage range: 9V~32V		
13				
12	GND	Power to		
5	5v output	Supply current is 200 mA		
35	download	Program download enables the port		
3	CAN1-H	None	None	Use only as a CAN communication interface, with support for CAN2.0B
4	CAN1-L	None	None	
6	RS232-TXD	None	None	
7	RS232-TXD	None	None	20 Connect DB9-3 / 1 Connect DB9-2. Serial port must be common
Port	Default setting	DI	Other	Remark
15	AI1	DI-101	None	AI/DI
16	AI2	DI-102		
17	AI3	DI-103		
18	AI4	DI-104		
19	AI5	DI-105		
20	AI6	DI-106		
22	AI7	DI-107		
21	AI8	DI-108	None	PI/DI
34	PI1	DI-201		
11	PI2	DI-202		
14	PI3	DI-203	CI01	DO/PWM/DI/CI
2	DO1/PWM1/CI1	DI-301		
8	DO2/PWM 2/CI2	DI-302		
9	DO3/PWM 3/CI3	DI-303		
10	DO4/PWM 4/CI4	DI-304	CI04	DO/PWM /DI
24	DO5/PWM 5	DI-305	None	
25	DO6/PWM 6	DI-306		
26	DO7/PWM 7	DI-307		
27	DO8/PWM 8	DI-308		
28	DO9/PWM 9	DI-309		
29	DO10/PWM 10	DI-310		
30	DO11/PWM 11	DI-311		
31	DO12/PWM 12	DI-312		
32	DO13/PWM 13	DI-313		
33	DO14/PWM 14	DI-314		
34	DO15/PWM 15	DI-315		
35	DO16/PWM 16	DI-316		

## Port Description

Quantity	Type	Description
8	AI/DI	DI: Switch quantity input, and the high level is effective AI: Analog input, can be set to 0-5 V voltage input or 0 ~ 20 mA current input, resolution of 12 bits
3	PI /DI	DI: Switch quantity input, and the high level is effective PI: Pulse input, 5 ~ 10 KHz, high level effective
12	DO / PWM/DI	DO: forward switch output, 0~3A, output shortcircuit protection PWM: 10 ~ 5 kHz, 0~3A, output short-circuit protection DI: Switch quantity input, and the high level is effective
4	DO / PWM / DI / CI	DO: forward switch output, 0~3A, output shortcircuit protection PWM: 10 ~ 5 kHz, 0~3A, outputshort-circuit protection DI: Switch quantity input, and the high level is effective Current detection function can be current control



## Equipment Applications



Controller connector  
776231-1



Sheath Wiring  
776164-1



Connector terminal  
3-1447221-3

## Outline Dimension

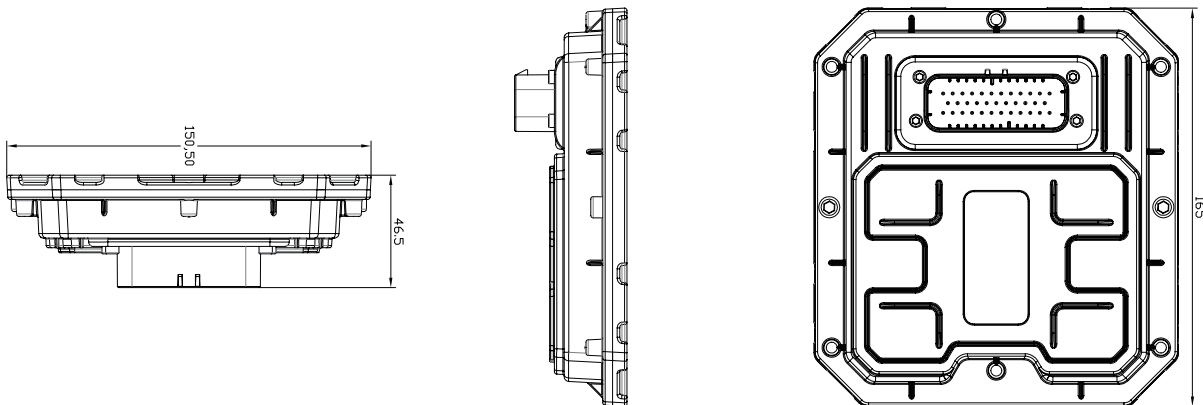

## Typical Application



## HHC-26C Controller

### Description

HHC-26C is a universal controller designed for mobile vehicles and engineering machinery control system, with high mechanical shock prevention and circuit protection characteristics compact and solid shape design, suitable for various harsh working environment; open, with rich input / output channel reuse, flexible configuration of ports, to enable more flexible, fast and accurate control system.



### Characteristic

- CAN Bus Interface
- Cast aluminum housing is solid and reliable, good heat dissipation performance IP67 protection grade
- IO function (software setting)
- Direct drive of the hydraulic valve

### Technical Parameter

Function	Parameter
Processor	32 bits, 72MHz
Program Space (FLASH)	256KB
Data Space (RAM)	64KB
Power-down save data space (FRAM)	512B
Working voltage	9V~32V
Continuous working current	12A@24V
No-load current	100mA@24V
Mechanical size (L×W×Hmm)	130*96*40
Install	Secure through 2 mounting holes (ø5.5mm)
Linkage	26 Needle plug-in
Weight	307g
Working temperature	-40 °C~ +85°C
Storage temperature	-40 °C~ +125°C
Levels of protection	IP67
Communication description of CAN interface	1 CAN interface, supporting CAN2.0B. 10 Kbits / s ~ 1 Mbits / s (default setting: 250 Kbits / s)
Input / output	Up to 19 inputs (occupying all communication interfaces) Up to 12 outputs and total IO up to 23 roads
Supporting electrical connection	TE Connectivity SUPER SEAL Series sheathes 3-1437290-8 Pin 3-1447221-3
Install	Vertical installation, installation hole spacing 119mm, M4 flat head screw * 2



## Pin Definition

Pin	Default setting	DI	Other	Description of pin definition
1	POWER+			With the current feedback function
2	DO1	None	PWM1	
3	DO2		PWM2	
4	DO3		PWM3	
5	DO4		PWM4	
6	DO5	DI-01	PWM5	The DI input high level is valid
7	DO6	DI-02	PWM6	
13	DO7	DI-05	PWM7	
19	DO8	DI-108	PWM8	
8	DO9	DI-03	PWM9	
14	DO10	DI-06	PWM10	
20	DO11	DI-07	PWM11	
21	DO12	DI-08	PWM12	
10	5Vout (200mA)			
15	AI1	DI-09		
16	AI2	DI-10		
17	AI3	DI-11		
18	AI4	DI-12		
12	AI5	DI-13		
11	AI6/DOWNLOAD	DI-14		
9	PI1	DI-15		
23	TX	DI-16		
22	RX	DI-17		
24	CAN-L	DI-18		
25	CAN-H	DI-19		
26	GND			

## Port Description

Quantity	Type	Description
5	AI/DI	DI: Switch quantity input, and the high level is effective AI: Analog input, can be set to 0~5V voltage input (0 ~ 20 mA current input optional), resolution of 12 bits
1	PI /DI	DI: Switch quantity input, and the high level is effective PI: Pulse input, 5 ~ 10 KHz, high level is effective
4	DO / PWM	DO: Forward switch output, 0~3A, output short-circuit protection PWM: 10 ~ 5 kHz, 0~3A, output short-circuit protection
4	DI	DI: Switch quantity input, and the high level is effective
8	DO / PWM / DI	DO: Forward switch output, 0~3A, output short-circuit protection PWM: 10 ~ 5 kHz, 0~3A, output short-circuit protection DI: Switch quantity input, and the high level is effective

## Electrical Interface



Controller connector  
776231-1



Sheath Wiring  
776164-1



Connector terminal  
3-1447221-3

## Outline Dimension

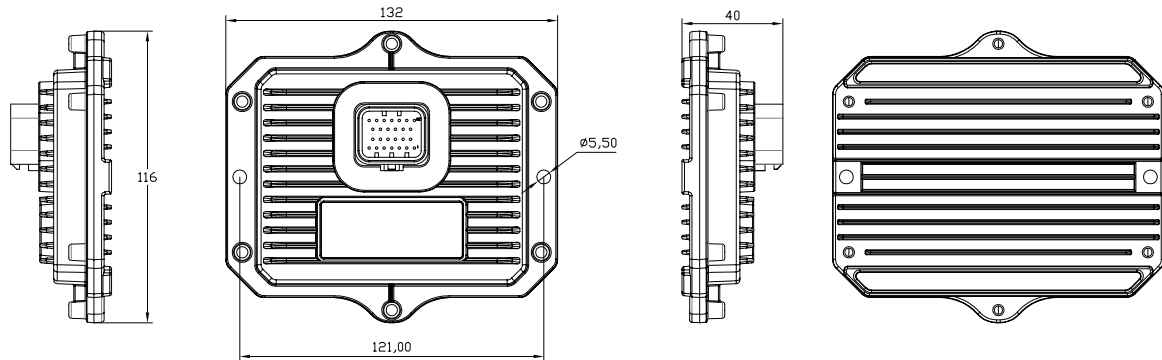

## Typical Application

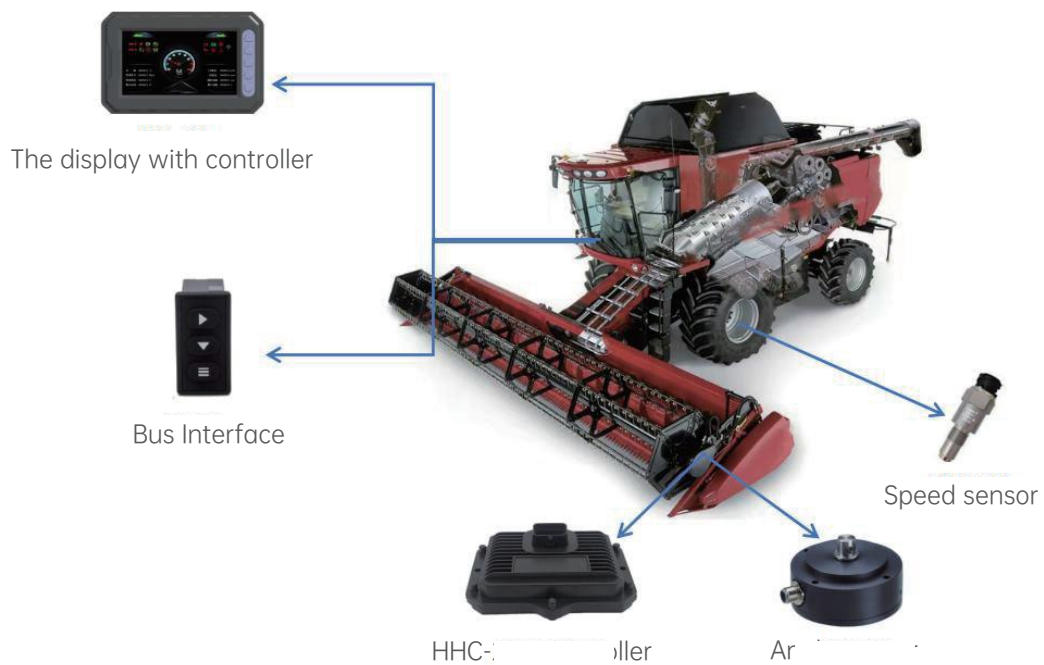



## HHC-24A Sensing Controller

### Description

HHC-24A is a general controller product suitable for most complex working conditions and construction machinery industry. High stability, flexible port configuration capabilities and excellent cost performance, to provide ideal solutions for a variety of industrial and construction machinery applications. The typical application case is used as a sensing controller to realize an active safety technology for safe driving by collecting a series of signals such as seat sensor, seat belt sensor, weight sensor and height sensor installed in the driving seat. Compliance with the relevant specification requirements of TSG 81-2022 the Safety Technical Regulations for Special Motor Vehicles in Field (Factory).



### Characteristic

- Meet the requirements of the national security technical specifications
- Compact shape design and solid, flexible installation, engineering plastic shell IP65 protection grade
- Powerful load; IO function (software setting)
- Direct drive of the hydraulic valve

### Technical Parameter

Function	Parameter
Processor	32 bits, at 72 MHz
Program Space (FLASH)	64KB
Data Space (RAM)	20KB
Working voltage	9V~32V
Continuous working current	8~10A@24V (determined by the power supply cable)
No-load current	10mA@24V
Mechanical size (L×W×H mm)	133*119*38
Install	Two mounting holes are fixed (ø8mm)
Weight	234g
Working temperature	-40 °C~ +85°C
Storage temperature	-40 °C~ +125°C
Levels of protection	IP65
Communication description of CAN interface)	1 CAN interface, supporting CAN2.0B. 10 Kbits / s ~ 1 Mbits / s (default setting: 250 Kbits / s)
IO port	Input 10, output 10, total I020
Supporting electrical connection	DTM 13-12PA-12 PB-R008, sheath DTM 06-12SA and DTM 06-12 SB

## Technical Parameter

Test Item	Test Standard	Test Performance
EMC	ISO7637	Road vehicles-Electromagnetic harassment caused by conduction and coupling
	GB/T 17619-1998	Limit of electromagnetic radiation immunity of motor vehicle electronics assembly
Environment	GB/T 28046.2-2011 standard 4.2	Product operating voltage range / DC power supply voltage
	QC/T 413-2002 standard 3.1.4	
	GB/T 28046.2-2011 standard 4.3	Overvoltage test
	GB/T 28046.2-2011 standard 4.7	Reverse voltage test
	GB/T 28046.2-2011 standard 4.10	Open circuit test, short circuit protection test
	GB/T 28046.2-2011 standard 4.11	Voltage resistance test
	GB/T 28046.2-2011 standard 4.12	Insulation resistance test
	GB/T 28046.3-2011 standard 4.1	Vibration test
	GB/T 28046.4-2011 standard 5.1.1	Thermocycling
	GB/T 28046.4-2011 standard 5.1.2	
	GB/T 28046.4-2011 standard 5.2	Temperature gradient test
	GB/T 28046.4-2011 standard 5.3	Temperature cycle test
	GB/T 28046.4-2011 standard 5.5	Salt-resistant fog test
	GB/T 28046.4-2011 standard 5.6	Hot and humid cycle test
GB/T 28046.4-2011 standard 5.7	Steady state hot and humid test	

## Performance Testing

Test item	Port	Default setting	Other	Remarks
A1	1	POWER+		Power positive pole
A2	2	DI09		Input high level is valid
A3	3	DOL01		Low edge output
A4	4	DI02		Input high level is valid
A5	5	DI03		
A6	6	DI04		
A7	7	DI05		
A8	8	DI06		
A9	9	DI07		
A10	10	DI08		
A11	11	5Vout	CAN-L	
A12	12		CAN-H	
B1	13	DI01		DI input high level is valid
B2	14	DO01		
B3	15	DO02		
B4	16	DO03		
B5	17	DO04		
B6	18	DO05		
B7	19	DO06		
B8	20	DO07		
B9	21	DO08		
B10	22	DO09		
B11	23	AI/PI		
B12	24	GNDI		Power negative pole



## Port Description

Type	Quantity	Available port	Description
DO	9	14、15、16、17、18、19、20、21、22	Forward switch output, 0~3A, output short circuit and overload protection, high side output
DOL	1	3	Low side output, 0~3A, output short circuit protection
DI	9	2、4、5、6、7、8、9、10、13	Switch volume input, high level effective, overvoltage protection High level gate limit voltage: high>3.5V Low-level gate limit voltage: low<1.5V
AI	1	23	■ Analog quantity input Voltage range: 0~5V Sampling accuracy: 12bit
PI	1	23	Pulse input, 1 Hz ~ 10 kHz, high level effective high level gate limit voltage: high>3.5V Low-level gate limit voltage: low<1.5V

## Electrical Interface

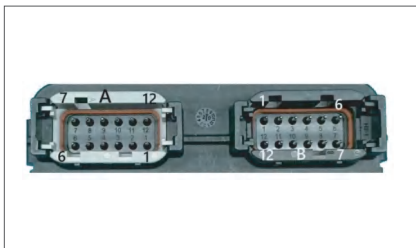

Controller connector  
DTM13-12PA-12PB-R008

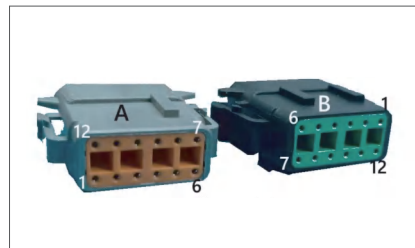

Sheath Connector  
DTM06-12SA Gray  
DTM06-12SB Black



Contact core  
0462-005-20141

## Outline Dimension

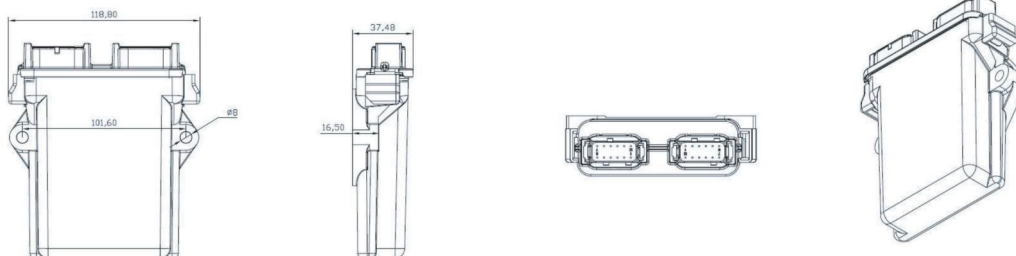

## Typical Application





## HHDC-40I The Display With Controller

### Description

HHDC-40I is a 4-inch LCD product with powerful performance, convenient development and high cost performance based on the application of logistics forklift. With integrated display with controller functions, exquisite display and beautiful graphical interface; highly integration, space saving and the ability to extend to sanitation, agricultural machinery, construction machinery, garden industry and other industries.



### Characteristic

- Customizable in appearance
- Customize the software / hardware
- Surface protection grade IP65
- Dual-way CAN 2.0 interface is compatible with J1939 protocol
- 10-way configurable IO port
- 800 \* 480 high resolution, optional touch screen

### Technical Parameter

Function	Parameter
Display screen	4-inch single-point capacitive screen, resolution of 800 * 480, 64 real colour
Memory	32M
Luminance	400 lumen
Visual Angle	85/85/85/85
Backlight life	50000Hrs
Processor	32-position, 480 MHZ
Working voltage	9V~32V
Continuous working current	8A@24V (as determined by the power supply cable)
No-load current	200mA@12V, 100mA@24V
Mechanical size (L x W x H mm)	152*93*58
Weight	263g
Working temperature	20 °C~ +70°C
Storage temperature	-30 °C~ +85°C
Levels of protection	IP65
Mode of operation	Touch screen, four physical buttons
Communication Description of CAN interface	Dual CAN interface, supporting CAN2.0B.10 Kbits / s ~ 1 Mbits / s (250kbps with default setting)
Port IO	I010 input, 6 input (including AI two roads), 4 output, single DO output 2A@24V
Matching electrical connections	TE Connectivity SUPER SEAL Series Sheath 3-1437290-8 Pin 3-1447221-3
Mounting	Embedded ball support



## Performance Testing

Test Item	Testing Standard	Test Performance
EMC	EN 12895:2015	Electromagnetic compatibility of industrial vehicles
	IEC 61000-4-6	RF electromagnetic field radiation immunity test
	ISO 7637-2-2011	Electrostatic discharge immunity test
Electrical transient conduction along the power line		
Environment	QCT 727-2017	High-temperature resistance performance test
		Low-temperature resistance performance test
		Temperature and humidity resistance cycle change test
		Vibration performance test
		Dust proof performance test
		Waterproof performance test
		Salt spray resistance performance test

## Port Definition

Pin	Default Setting	Other	Description of pin definition
1	POWER+		Power positive pole
2	DO1	PWM1	DO high level output, maximum current 2A
3	DO2	PWM2	DO high level output, maximum current 2A, with current feedback detection
4	DO3	PWM3	DO high level output, maximum current 2A
5	DO4	PWM4	DO high level output, maximum current 2A
6	DOWNLOAD		High level goes into download mode
7	DI1		DI input high level is valid
8	DI2		DI input high level is valid
9	DI2		DI input high level is valid
10	5V-out		5Voutput with a maximum of 200 mA
11	AI1		0~5V voltage input or 4 ~ 20 mA current input or resistance input
12	AI2		12 AI2 0
13	-		
14	-		
15	DI4		DI input high level is valid
16	-		
17	-		
18	-		
19	-		
20	RS232-RX		
21	RS232-TX		
22	CAN1-L		
23	CAN1-H		
24	CAN2-L		
25	CAN2-H		
26	GND		Power negative pole

## Port Description

Type	Quantity	Available port	Description
DO	4	2, 3, 4, 5	Support high level output, with current feedback detection (port 3), output short circuit protection, maximum output current 2A, PWM output function.
DI	4	7, 8, 9, 15	Switch quantity input, high level effective, overvoltage protection: Switch on-threshold voltage: high>3.5V; Switch off-threshold voltage: low<1.5V
AI	2	11, 12	Voltage input(overvoltage protection) Detection range:0~5V. Sampling accuracy: 12 bits Detection accuracy:± 1.0%FS Input impedance: 95 KΩ
			■ Current input Detection range:0 ~ 20 mA Sampling accuracy: 12 bits Detection accuracy: ±1.0%FS Input impedance: 249 KΩ
			■ Resistance input Detection accuracy: load-related Input impedance: 95 KΩ

## Electrical Interface



Controller connector  
AMP 6473418-1



Sheath terminal  
3-1437290-8



Connector terminal  
3-1447221-3

### Outline Dimension

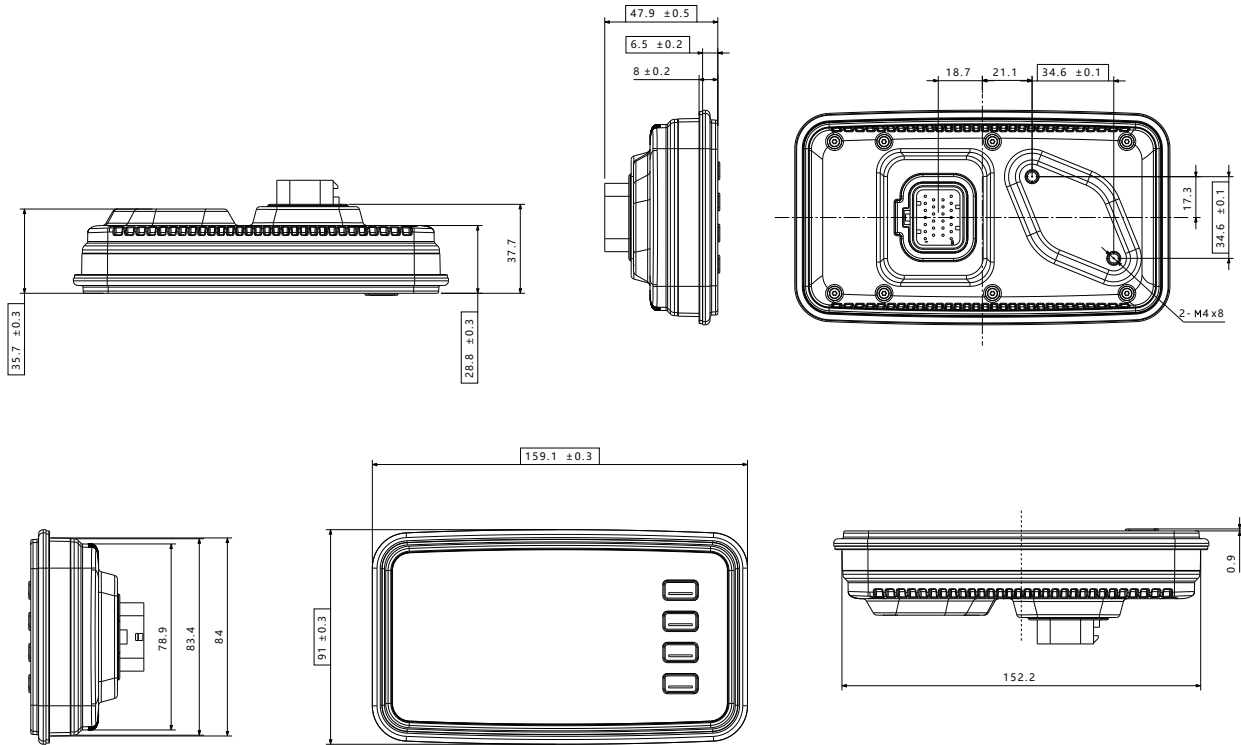

### Typical Application

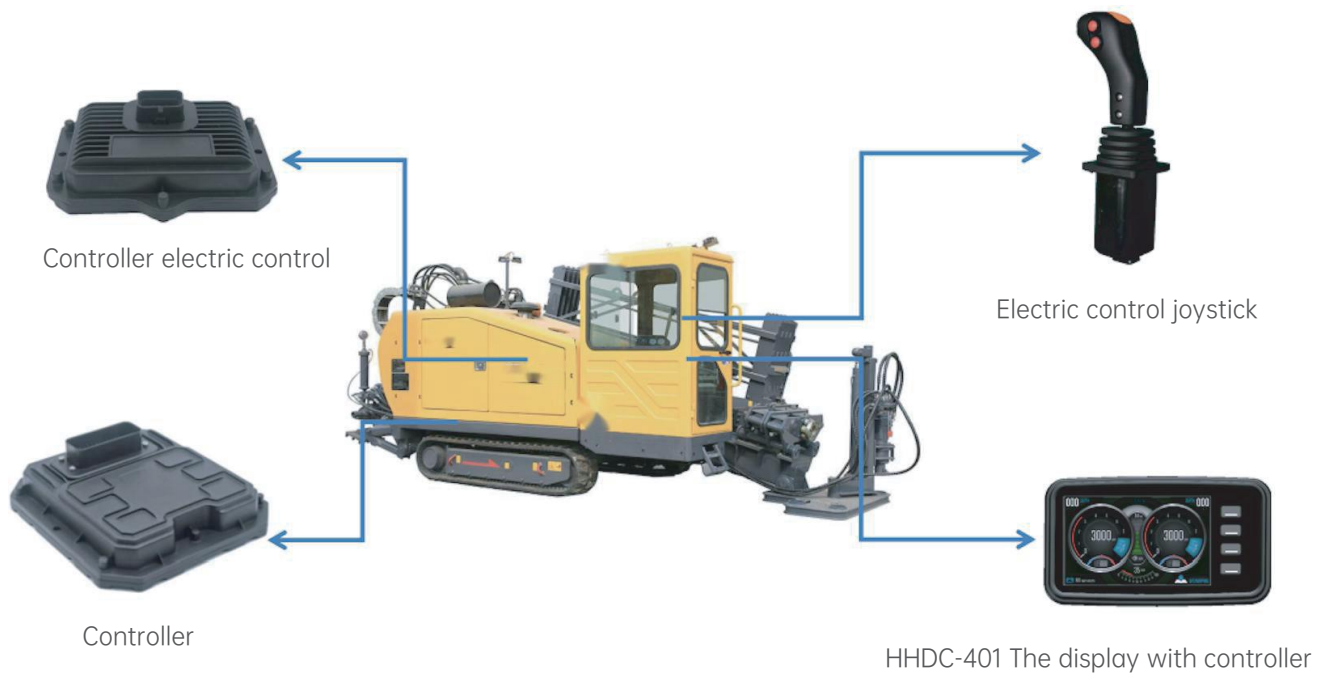



## HHDC-70L The Display With Controller

### Description

HHDC-70L is an integrated display with controller product with high performance, high protection and high reliability. Using high brightness backlight display, can be clearly visible even in strong light, the user interface can be freely programmed development. Ability to adapt to harsh conditions. Suitable for construction machinery, mining card vehicles, logistics forklift trucks, special vehicles and other fields.



### Characteristic

- Customize the software / hardware
- Two-way camera interface
- Metal housing is solid and reliable, good heat dissipation performance, protection grade IP67
- CAN 2.0 interface, compatible with J1939 protocol
- IO Functions (software setting)
- 800 \* 480 high resolution, optional touch screen



## Technical Parameter

Function	Parameter
Display screen	7-inch single-point capacitive screen, resolution of 800 * 480,64K true colour
Memory	512M
luminance	450 lumen
Visual Angle	85°/85°/85°/70°
Backlight life	50000Hrs
Processor	32 bits, 168MHZ
Working voltage	9V~32V
Continuous working current	8A@24V (as determined by the power supply cable)
No-load current	400mA@12V, 200mA@24V
Mechanical size (L x W x H mm)	219*143*37
Weight	845g
Working temperature	-20 °C~ +70°C
Storage temperature	-30 °C~ +85°C
levels of protection	IP67
Mode of operation	Touch screen / five physical buttons
Communication Description of CAN interface	Single-channel CAN interface, supporting CAN2.0B.10 Kbits / s ~ 1 Mbits/ s (250 kbps by default)
Port IO	I024 in maximum,input max.15 ways, ouput max. 9 ways, and single port. DO 3A@24V
Supporting electrical connection	TE Connectivity SUPER SEAL Series sheath 776164-1
Install	Embedded or ball support installation

## Performance Test

Test Item	Test Standard	Test Performance
EMC	EN 12895:2015	Electromagnetic compatibility of industrial vehicles
	IEC 61000-4-6	RF electromagnetic field radiation immunity test
	ISO 7637-2-2011	Electrostatic discharge immunity test
Electrical transient conduction along the power line		
Environment	QCT 727-2017	High-temperature resistance performance test
		Low-temperature resistance performance test
		Temperature and humidity resistance cycle change test
		Vibration performance test
		Dust proof performance test
		Waterproof performance test
		Salt spray resistance performance test



## Port Definition

Pin	Default setting	DI	Other	Description of pin definition
1	POWER+			Power positive pole
2	DO04		PWM04	DO high-level output, with a maximum current of 2A
3	DO03		PWM03	Output short-circuit protection, current feedback detection
4	DI03			Switch volume input, the high level is valid, with overvoltage protection
5	DI04			
6	AI01			The AI can be set to 0 to 5 V voltage input or 0-20 mA current input
7	PI01	DI12		PI pulse input, 5 to 10 KHz high level is valid
8	PI02	DI13		
9	PI03	DI14		
10	PI04	DI15		
11	DO02		PWM02	DO high-level output, with a maximum current of 2A
12	DO01		PWM01	Output short-circuit protection, current feedback detection
13	DI02			Switch volume input, the high level is valid, with overvoltage protection
14	DI01			
15	VEDIO-A			A channel camera video signal input
16	DI06			Switch volume input, the high level is valid, with overvoltage protection
17	AI03			The AI can be set to 0 to 5 V voltage input or 4 to 20 mA current input
18	VEDIO-B			B-channel camera video signal input
19	5VOUT			5V voltage output
20	AI04			The AI can be set to 0 to 5 V voltage input or 4 to 20 mA current input
21	USB D-			Display screen program upgrade interface
22	USB D+			
23	DO09		PWM08	DO high-level output, with a maximum current of 2A
24	DO05		DOWNLOAD	DO high-level output, with a maximum current of 2A
25	DO06		PWM05	DO high-level output, with a maximum current of 2A
26	DI07			Switch volume input, the high level is effective, with overvoltage protection
27	DI05			Switch input, high level is valid, overvoltage protection
28	DO07		PWM06	DO high-level output, with a maximum current of 2A
29	DO08		PWM07	
30	AI02			The AI can be set to 0 to 5 V voltage input or 4 to 20 mA current input
31	CAN-L			CAN communication interface
32	CAN-H			CAN communication interface
33	RS232-RX			Program download and monitoring interface
34	RS232-TX			
35	GND			Power negative pole



## Port Description

Type	Quantity	Available Port	Description
DO	4	2, 3, 11, 12	Support high level output, output short circuit protection, current feedback detection, maximum output current 2A
DO	5	23, 24, 25, 28, 29	Support high and low level output, output short circuit, overload protection, maximum output current 3A
DI	6	4, 5, 13, 14, 16, 27	Switch volume input, high level effective, overvoltage protection: Switch on-threshold voltage: high > 3.5V Switch / off-threshold voltage: low < 1.5V
D1-	1	26	Switch volume input, low level input is effective, 0~1.5V, overvoltage protection
AI	4	6, 17, 20, 30	■ Voltage input (overvoltage protection) Detection range: 0~5V.      Sampling accuracy: 12 bits Detection accuracy: ±1.0%FS      Input impedance: 95 KΩ
			■ Voltage input Detection range: 0~5V.      Sampling accuracy: 0 ~ 20 mA Detection accuracy: ±1.0%FS      Input impedance: 249 KΩ
			■ Resistance input Detection accuracy: load-related input impedance: 95 KΩ
PI	4	7, 8, 9, 10	Pulse input, 5 ~ 10 kHz, high level effective: Switch on-threshold voltage: high > 3.5V Switch / off-threshold voltage: low < 1.5V
PWM	4	2, 3, 11, 12	Forward output, 10-5 kHz, 0~2A, output short circuit, overload protection, current feedback detection
PWM	4	23, 25, 28, 29	Forward output, 10-5 kHz, 0~2A, output short circuit, overload protection

## Electrical Interface



Controller connector  
776231-1



Sheath wiring  
776164-1



Connector terminal  
3-1447221-3

## Outline Dimension

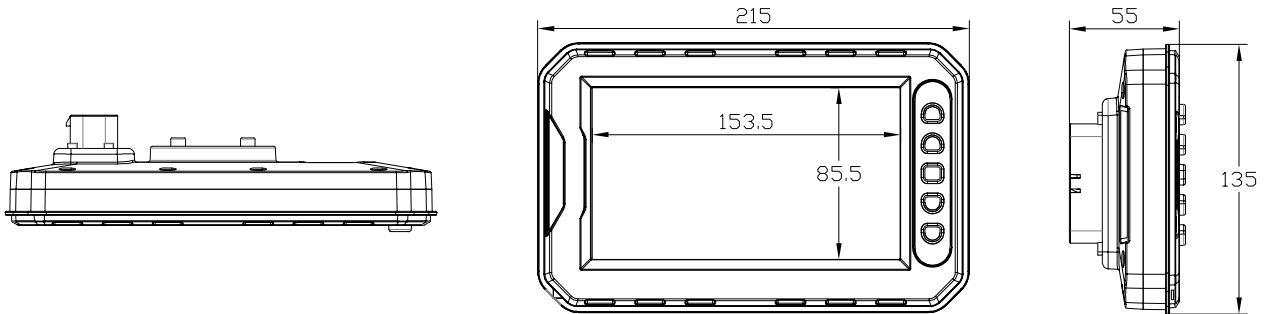

## Typical Application

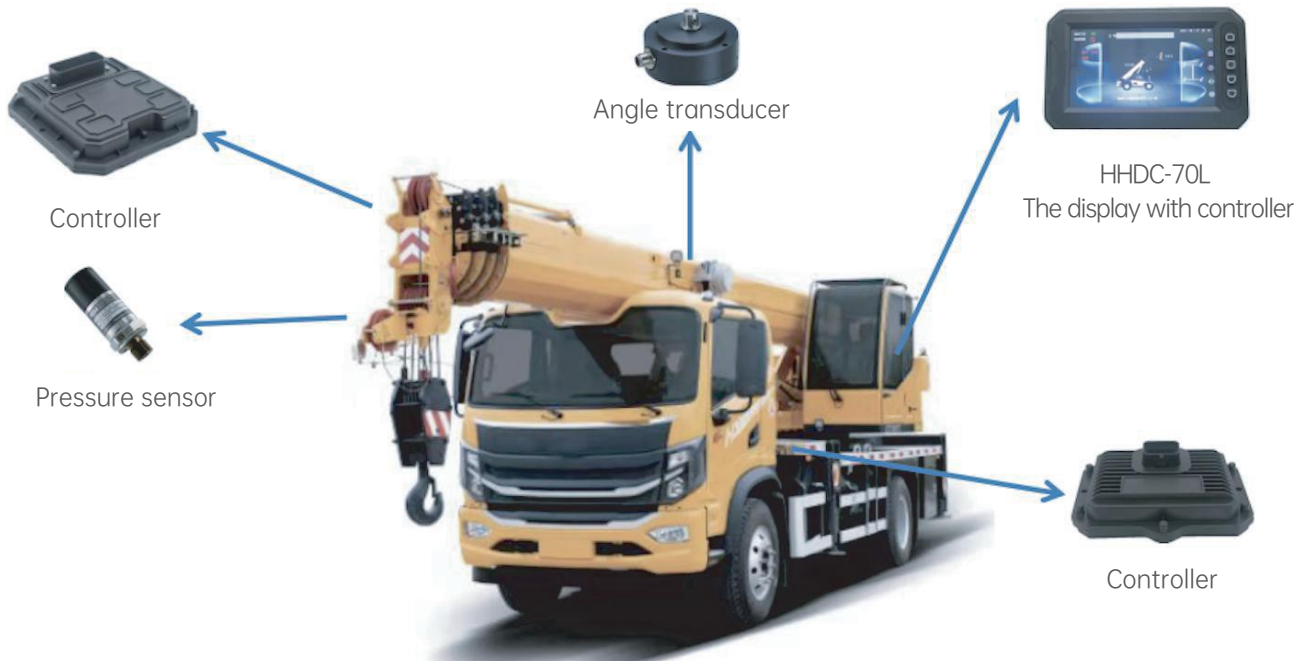



## HHH-26B Smart Shift Joystick

### Description

HHH-26B is a shift control joystick developed for roller and grader. It has built-in controller, which can realize the functions of the increase or decrease of gear, and has some functions of VCU.

The intelligent shift operation joystick follows the principle of ergonomics, has a comfortable feel, while ensuring the high reliability and accuracy of the operation, with a wide range of application.



### Characteristic

- CAN Bus Interface
- IP65 protectionlevel (top)
- IO function (software setting)
- Application in harsh environments
- Direct drive of the hydraulic valve
- Typical applications: roller series, loader series, grader series and other equipment equipped with hydraulic gear shifting transmission

### Technical Parameter

Function	Parameter
Processor	32 bits, 72MHZ
Program Space (FLASH)	256KB
Data Space (RAM)	64KB
Power-down save data space (FRAM)	512B
Working voltage	9V~32V
Continuous working current	12A@24V is determined by the power supply cable, and the maximum amount is 15A@24V
No-load current	100mA@24V
Mechanical size (L x W x H mm)	78*78*298
Install	4 mounting holes fixed (5 mm)
Linkage	26 Needle plug-in
Weight	1.1 kg
Working temperature	-40 °C~ +85°C
Storage temperature	-40 °C~ +125°C
Levels of protection	IP65 (above the mounting panel)
CAN joggle	1 CAN interface, supporting CAN2.0B.
Communication description	10 Kbits / s ~ 1 Mbits / s (default setting 250 kbps)
Import	5 Road
Output	9 Road
Supporting electrical connection	TE Connectivity SUPER SEAL Series sheath 3-1437290-8 Pin 3-1447221-3
Install	Flat installation, installation hole spacing of 61mm, M4 flat head screw * 4



## Port Definition

Port Definition	Pin Meaning	Note description (Take the Hangtooth gearbox as an example Pin meaning)
6	DO01	M3 solenoid valve
7	DO02	M4 solenoid valve
13	DO03	M1 solenoid valve
19	DO04	M2 solenoid valve
2	DO05	Vibration output
3	DO06	Reserved output
4	DO07	Backshift output
5	DO08	Empty output
14	DO09	Reserved output
18	DI01	Parking input
17	DI02	Small vibration input
11	DI03	Large vibration input
12	DI04	Clutch input
20	PI01	Speed input
9	Download the enabling port	Valid high level
1	POWER+	—
8	POWER+	—
10	GND	—
15	GND	—
16	GND	—
21	GND	—
26	GND	—
22	RS232-RX	—
23	RS232-TX	—
24	CAN-L	—
25	CAN-H	—

## Port Description

Quantity	Type	Description
8	DO	High-level output (with current feedback)
1	DO	High-level output (without current feedback)
3	DI	high-level input
1	DI	Low level input
1	PI	Impulse input

## Customized Button Function

Button	Key Function	Note (Take the roller for example)
Button1	Custom features	Increase gear
Button2	Custom features	File reduction
Button3	Custom features	Big vibration
Button4	Custom features	Small vibration
Front and rear handle signal	Custom features	Forward / backward

### Electrical Interface



Controller Connector  
AMP 6473418-1



Sheath wiring  
3-1437290-8



Connector terminal  
3-1447221-3

### Outline Dimension

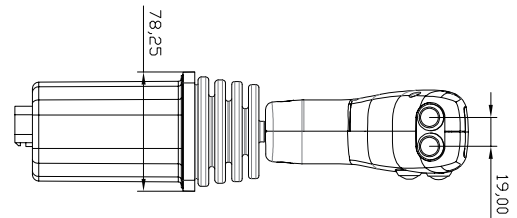
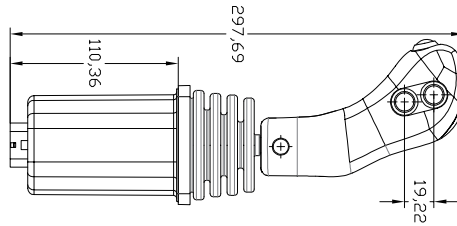
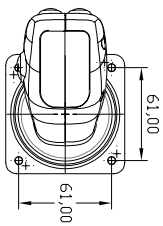

### Typical Application



HHH-268 Electrical joystick

The display with controller

Controller

Sensing controller

## HHS-6A Bus button switch

### Description

The HHS-6A product is installed in the cab and communicates with the vehicle controller and monitor through the CAN bus. The product is equipped with three silicone buttons, which can independently define the function of each button, and send the signal to the vehicle control system through the CAN bus. The product is compact and compact, with long service life and good operation feel.



### Characteristic

- CAN bus interface
- IP65 protection grade
- Application in harsh environments
- Card buckle installation, easy to use

### Technical Parameter

Function	Parameter
Processor	32 bits, 72MHZ
Program Space (FLASH)	64KB
Data Space (RAM)	20KB
Working voltage	9V~36V
Continuous working current	Maximum of 1A@12V
No-load current	20mA@12V
Mechanical size (L x W x H mm)	50*56.5*26
Weigh	27g
Working temperature	-40 °C~ +85°C
Storage temperature	-40 °C~ +85°C
Levels of protection	IP65
CAN joggle	1 CAN interface, supporting CAN2.0B. 10 Kbits / s ~ 1 Mbits / s (250 kbps with default setting)
Port IO	Output 1 road
Supporting electrical connection	6 Pin connector: pin holder 5569-6 AW; connector model Molex39-01-2060
Installation	Buckle installed



## Port Definition

Port	Default Setting	Description
1	POWER+	Power positive pole
2	DOL01	To the ground output
3	CAN-H	
4	GND	Power anode
5	5Vout	200mA
6	CAN-L	

## Port Description

Type	Quantity	Optional Port	Description
DOL	1	2	Low-side output, load current 0-1A

## Electrical Interface



Bus switch pin holder 5569-6AW



Connector Molex39-01-2060

## Outline Dimension

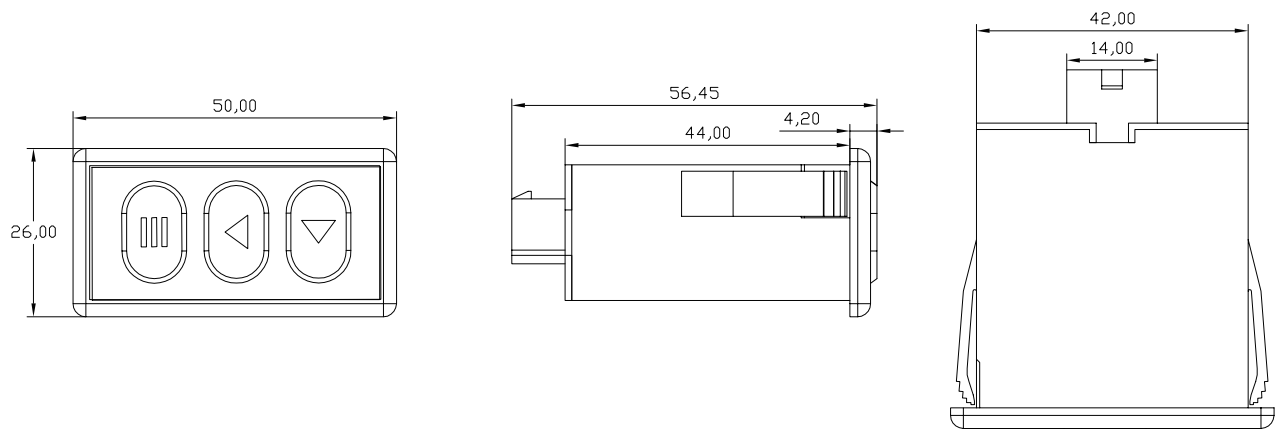

### Typical Application





**Shanghai Ryan Hydraulic Fluid Power Co., Ltd**

Add. Room 2201-2202, 1717 North Sichuan Road,  
Hongkou Shanghai, China  
P.C. 200080  
Tel. +86-21-5662 6882  
Mail. sales@ryanhydraulic.com

